

Thank you for purchasing a Sony Ericsson W350a.
Enjoy your music wherever you go.

For additional phone content, go to
www.sonyericsson.com/fun.

Register now to get a suite of tools, free online
storage, special offers, news and competitions
at *www.sonyericsson.com/myphone*.

For product support, go to *www.sonyericsson.com/support*.

Accessories – More for your Phone

Portable Speakers MPS-70

Small yet powerful speakers that fit in your pocket



Stereo Portable Handsfree HPM-83

Street-style neck band headset with superior audio performance



Stereo Bluetooth™ Headset HBH-DS200

Enjoy wireless music without missing a call



These accessories can be purchased separately but may not be available in every market. To view the full range go to www.sonyericsson.com/accessories.

This is the Internet version of the User guide. © Print only for private use.

Contents

Getting Started 5

Assembly	5
Turning On the Phone	6
Help in Your Phone	7
Charging the Battery	8
Phone Overview	9
Menu Overview	11
Status Bar Icons	12
Navigation	13
Shortcuts	15
File Manager	15
Phone Language	17
Entering Text	17

Walkman® and Music 18

Transferring Content to and from a Computer	18
Walkman® Player	19
PlayNow™	21
TrackID™	22

Calling 22

Making and Receiving Calls	22
Emergency Calls	23
Contacts	23

Groups	26
Call List	26
Speed Dial	26
Voicemail	27
Forwarding Calls	27
More than One Call	27
Handling Two Voice Calls	28
Conference Calls	28
My Numbers	29
Accept Calls	29
Restricted Dialing	29
Fixed Dialing	30
Call Time and Cost	30
Business Cards	30

Messaging 31

Text Messages	31
Picture Messages	32
Templates	34
Voice Messages	34
Email	35
My Friends	37
Area and Cell Information	38

Imaging	39	Notes	56
Camera	39	Timer, Stopwatch and Calculator	57
Transferring Pictures	40	Code Memo	57
Pictures	41	Profiles	58
Entertainment	42	Time and Date	59
Radio	42	Themes	59
Ringtones and Melodies	42	Locks	59
MusicDJ™	43	IMEI Number	60
Sound Recorder	44	Troubleshooting	61
Video Player	44	Common Questions	61
Games	44	Error Messages	63
Applications	45	Important Information	64
Connectivity	46	Guidelines for Safe and Efficient Use	66
Settings	46	Limited Warranty	70
Using Internet	46	FCC Statement	72
RSS Reader	48	Declaration of Conformity for W350a	73
Bluetooth™ Wireless Technology	48	Index	74
Using the USB Cable	50		
Synchronizing	51		
Update Service	53		
More Features	54		
Alarms	54		
Calendar	54		
Tasks	56		

Sony Ericsson W350a

GSM 850/1800/1900

This User guide is published by Sony Ericsson Mobile Communications AB or its local affiliated company, without any warranty. Improvements and changes to this User guide necessitated by typographical errors, inaccuracies of current information, or improvements to programs and/or equipment, may be made by Sony Ericsson Mobile Communications AB or its local affiliated company at any time and without notice. Such changes will, however, be incorporated into new editions of this User guide.

All rights reserved.

©Sony Ericsson Mobile Communications AB, 2008

Publication number: 1209-1172.2

Please note:

Some of the services in this User guide are not supported by all networks. *This also applies to the GSM International Emergency Number 112.*

Please contact your network operator or service provider if you are in doubt whether you can use a particular service or not.

Please read the *Important information* chapters before you use your phone.

Your phone has the capability to download, store and forward additional content, for example ringtones. The use of such content may be restricted or prohibited by rights of third parties, including but not limited to restriction under applicable copyright laws. You, and not Sony Ericsson, are entirely responsible for additional content that you download to or forward from your phone. Prior to your use of any additional content, please verify that your intended use is properly licensed or is otherwise authorized. Sony Ericsson does not guarantee the accuracy, integrity or quality of any additional content or any other third party content. Under

no circumstances will Sony Ericsson be liable in any way for your improper use of additional content or other third party content.

Bluetooth is a trademark or registered trademark of Bluetooth SIG Inc. and any use of such mark by Sony Ericsson is under license.

The Liquid Identity logo, PlayNow, TrackID and MusicDJ are trademarks or registered trademarks of Sony Ericsson Mobile Communications AB.

Sony, Memory Stick Micro, M2, WALKMAN and the WALKMAN logo are trademarks or registered trademarks of Sony Corporation.

Ericsson is a trademark or registered trademark of Telefonaktiebolaget LM Ericsson.

Adobe and Photoshop are trademarks or registered trademarks of Adobe Systems Incorporated in the United States and/or other countries.

TrackID is powered by Gracenote Mobile MusicID™. Gracenote and Gracenote Mobile MusicID are trademarks or registered trademarks of Gracenote, Inc.

Microsoft, Windows, Outlook and Vista are trademarks or registered trademarks of Microsoft Corporation in the United States and/or other countries.

T9™ Text Input is a trademark or a registered trademark of Tegic Communications. T9™ Text Input is licensed under one or more of the following: U.S. Pat. Nos. 5,818,437, 5,953,541, 5,187,480, 5,945,928, and 6,011,554; Canadian Pat. No.

1,331,057, United Kingdom Pat. No. 2238414B;

Hong Kong Standard Pat. No. HK0940329; Republic of Singapore Pat. No. 51383; Euro.Pat. No. 0 842 463(96927260.8) DE/DK, FI, FR, IT, NL, PT, ES, SE, GB; and additional patents are pending worldwide.

Java and all Java based trademarks and logos are trademarks or registered trademarks of Sun Microsystems, Inc. in the U.S. and other countries.

End-user license agreement for Sun™ Java™ J2ME™.

Restrictions: Software is confidential copyrighted information of Sun and title to all copies is retained by Sun and/or its licensors. Customer shall not modify, decompile, disassemble, decrypt, extract, or otherwise reverse engineer Software. Software may not be leased, assigned, or sublicensed, in whole or in part.

Export Regulations: Software, including technical data, is subject to U.S. export control laws, including the U.S. Export Administration Act and its associated regulations, and may be subject to export or import regulations in other countries. Customer agrees to comply strictly with all such regulations and acknowledges that it has the responsibility to obtain licenses to export, re-export, or import Software. Software may not be downloaded, or otherwise exported or re-exported (i) into, or to a national or resident of, Cuba, Iraq, Iran, North Korea, Libya, Sudan, Syria (as such listing may be revised from time to time) or any country to which the U.S. has embargoed goods; or (ii) to anyone on the U.S. Treasury Department's list of Specially Designated Nations or the U.S. Commerce Department's Table of Denial Orders.

Restricted Rights: Use, duplication or disclosure by the United States government is subject to the restrictions as set forth in the Rights in Technical Data and Computer Software Clauses in DFARS 252.227-7013(c) (1) (ii) and FAR 52.227-19(c) (2) as applicable.

Other product and company names mentioned herein may be the trademarks of their respective owners.

Any rights not expressly granted herein are reserved.

All illustrations are for illustration only and may not accurately depict the actual phone.

Instruction Symbols

The following appear in the User guide.



Note



Tip



Warning



A service or function is network- or subscription-dependent. Contact your network operator for details.



Use a selection or navigation key to scroll and select. See *Navigation* on page 13.



Press the navigation key center.



Press the navigation key up.



Press the navigation key down.



Press the navigation key left.



Press the navigation key right.

Getting Started

Assembly

Before you start using your phone, you need to insert a SIM card and the battery.

- ! The battery must be removed before the SIM card is inserted or removed.

To insert the SIM card

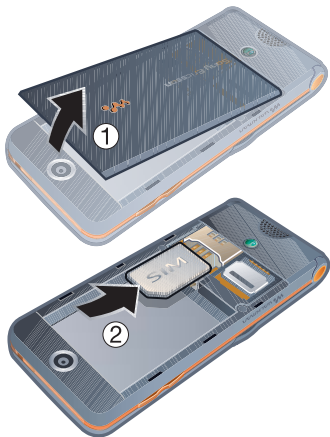

- 1 Remove the battery cover.
- 2 Slide the SIM card into its holder with the contacts facing down.

To insert the battery

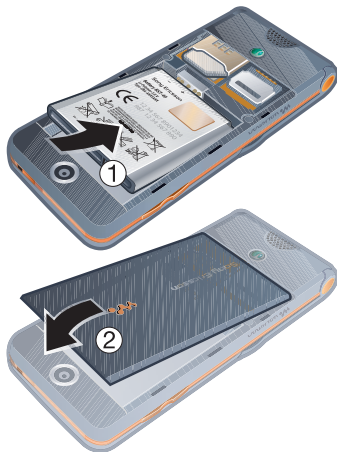

- 1 Insert the battery with the label side up and the connectors facing each other.
- 2 Replace the battery cover.

To remove the battery

- 1 Remove the battery cover.
- 2 Insert your fingernail in the indentation.
- 3 Remove the battery.

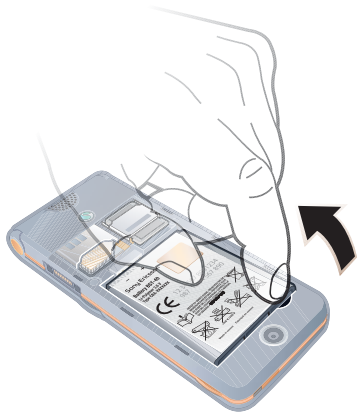

Turning On the Phone

To turn on the phone



- 1 Press and hold down **C**.
 - 2 Select a mode:
 - **Normal** – full functionality.
 - **Flight Mode** – limited functionality.
 - 3 Enter your SIM card PIN, if requested.
 - 4 Select a language.
 - 5 Select **Yes** to use the setup wizard.
- ! If you want to correct mistake when you enter your PIN, press **C**.

SIM card

The SIM (Subscriber Identity Module) card, which you get from your network operator, contains information about your subscription. Always turn off your phone and detach the charger and the battery before you insert or remove the SIM card.

- You can save contacts on the SIM card before you remove it from your phone. See *To copy names and numbers to the SIM card on page 24*.

PIN

You may need a PIN (Personal Identification Number) to activate the services in your phone. Your PIN is supplied by your network operator. Each PIN digit appears as *, unless it starts with emergency number digits, for example, 112 or 911. You can see and call an emergency number without entering a PIN.

To delete numbers from the display

- Press **(C)**.

- If you enter the wrong PIN three times in a row, **PIN Blocked** appears. To unblock it, you need to enter your PUK (Personal Unblocking Key). See *SIM card lock on page 59*.

Flight mode

In **Flight Mode** the network and radio transceivers are turned off to prevent disturbance to sensitive equipment.

- You can use the Bluetooth™ function in **Flight mode**.



Startup screen

The startup screen appears when you turn your phone on. See *Using pictures on page 41*.

Standby

After you have turned your phone on and entered your PIN, the name of the network operator appears on the screen. This is called standby.

Help in Your Phone

Help and information is available in your phone at any time. See *Navigation on page 13*.

To use the setup wizard

- 1 From standby select **Menu** > **Settings** > the **General** tab > **Setup Wizard**.
- 2 Select an option.

To view information about functions

- Scroll to a function and select **Info**, if available. In some cases, **Info** appears under **More**.

To view the phone demonstration

- From standby select **Menu** > **Entertainment** > **Demo Tour**.

Settings download

You can download settings to your phone. These settings let you use functionality that require Internet accounts, for example, picture messaging and email.

To download settings

- From standby select [Menu > Settings > the General tab > Setup Wizard > Settings Download](#).

! Contact your network operator or service provider for more information.

Charging the Battery

The phone battery is partly charged when you buy it.

To charge the battery



- 1 Connect the charger to the phone. It takes approximately 2.5 hours to fully charge the battery.
- 2 Remove the charger by tilting the plug upwards.

💡 You can use your phone while it is charging. You can charge the battery at any time and for more or less than 2.5 hours. You can interrupt the charging without damaging the battery.

Phone Overview

- 1 Music key lock
- 2 Walkman® player control
- 3 Screen
- 4 Selection key
- 5 Back key
- 6 Connector for charger, handsfree and USB cable
- 7 Clear key On/off key
- 8 Navigation key
- 9 Silent key
- 10 Fast forward (music key)
- 11 Play/Pause/Stop (music key)
- 12 Rewind (music key)
- 13 The flip



- 14 Camera lens
- 15 Volume, adjust brightness buttons
- 16 Loudspeaker



Menu Overview



PlayNow™*



Internet*



Entertainment

Online Services*
Games
TrackID™
Video Player
MusicDJ™
Record Sound
Demo Tour



Camera



Messaging

Write New Sent Messages
Inbox Saved Messages
Email My Friends*
RSS Reader Call Voicemail
Drafts Templates
Outbox Settings



WALKMAN



File Manager**



Contacts



Radio



Calls**



All



Answered



Dialed



Missed



Organizer

Alarms
Applications
Calendar
Tasks
Notes
Synchronization
Timer
Stopwatch
Calculator
Code Memo



Settings**



General
 Profiles
 Time & Date
 Language
 Update Service
 New Events
 Shortcuts
 Flight Mode
 Security
 Setup Wizard
 Phone Status
 Master Reset



Sounds & Alerts
 Ring Volume
 Ringtone
 Silent Mode
 Increasing Ring
 Vibrating Alert
 Message Alert
 Key Sound



Display
 Wallpaper
 Themes
 Startup Screen
 Screen Saver
 Brightness
 Edit Line Names*



Calls
 Speed Dial
 Forward Calls
 Switch to Line 2*
 Manage Calls
 Time & Cost*
 Show/Hide My No.
 Handsfree
 Open to Answer



Connectivity
 Bluetooth
 USB Connection
 Synchronization
 Device Mgmt.
 Mobile Networks
 Data Comm.
 Internet Settings
 Accessories

* Some menus are operator-, network- and subscription-dependent.

** You can use the navigation key to scroll between tabs in submenus. For more information, see Navigation on page 13.

Status Bar Icons

Some of these icons may appear on the screen to show status and new events.

Icon Description



GSM network signal strength



Battery status



Battery charging, appears with battery status icon



Missed incoming call



Text message received



Email message received



Picture message received



Voice message received



Ongoing call



Handsfree is connected



Radio playing in the background



Calendar reminder



Task reminder

Navigation

The main menus are shown as icons.
Some submenus include tabs.

To navigate the phone menus







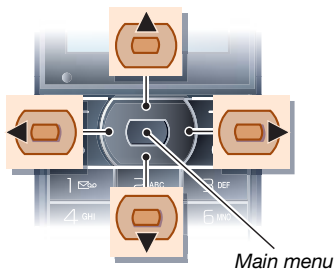

- 1 From standby select **Menu**.
- 2 Use the navigation key to move through the menus.









To scroll between the tabs

- Scroll to a tab by pressing the navigation key left or right.



Key

	Go to the main menus or select items
	Scroll between the menus and tabs
	Select options shown immediately above these keys on the screen.
	Go back one level in the menus. Press and hold down to return to standby or end a function.
	Delete items, such as pictures, sounds and contacts. Press and hold down to mute the microphone during a call. Turn the phone on/off.
	Open the Walkman® player. Press to move between the Walkman® player and the music files.
	Press and hold down to call your voicemail service (if set).
 - 	Press and hold down a number key to reach a contact beginning with a specific letter.

 - 	Press a number key and select Call to speed dial.
	Press to turn off the ringtone when you receive a call. Press and hold down to set the phone to silent. The alarm signals even if your phone is set to silent.
	Press to change letter case when writing a message. Press and hold to toggle T9™ Text Input on and off when writing a message.
	On the flip: Stop, pause and play (music key). When you close the flip you turn on the Walkman® player. Press to automatically search for radio channels. Press up or down to search for preset channels.
	On the flip: Skip to the previous track when using the Walkman® player. Search for radio channels.
	On the flip: Skip to the next track when using the Walkman® player. Search for radio channels.
	On the side of the phone: View status information in standby. Increase the volume during a call, or when you use the Walkman® player. Increase brightness when you use the camera. Press twice to reject a call. In standby, press once to mute an incoming call.
	On the side of the phone: Decrease the volume during a call, or when you use the Walkman® player. Decrease brightness when you use the camera

Shortcuts

You can use keypad shortcuts to go directly to a menu. Menu numbering starts from the top left icon and moves across and then down row by row.

To go directly to the seventh menu

- From standby select **Menu** and press **(7)**.

To use navigation key shortcuts

- From standby press **(Up)**, **(Down)**, **(Left)** or **(Right)** to go directly to a function.

To edit a navigation key shortcut

- From standby select **Menu > Settings > the General tab > Shortcuts**.
- Scroll to an option and select **Edit**.
- Scroll to a menu option and select **Shortcut**.

File Manager

You can use the file manager to handle items saved in the phone memory or on a memory card.

! You may have to purchase a memory card separately.

Memory card

Your phone supports Memory Stick Micro™ (M2™) memory card adding more storage space to your phone. It can also be used as a portable memory card with other compatible devices.

To insert a memory card

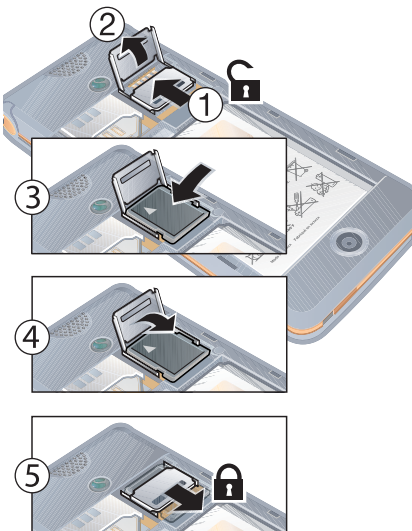

- Open the memory card holder.
- Insert the memory card with the gold-colored contacts facing down.
- Close the memory card holder.
- Slide the memory card holder to lock it.
- Replace the battery cover.

To view memory card options

- 1 From standby select **Menu > File Manager >** the **On Memory Stick** tab.
- 2 Select **More**.

Handling files

You can move and copy files between your phone, a computer and a memory card. Files are saved on the memory card first and then in the phone memory. Unrecognized files are saved in the **Other** folder.

You can create subfolders to move or copy files to. When you handle files, you can select more than one or all the files in a folder at the same time for all items except **Games** and **Applications**.

If the memory is full, delete some content to create space.

File manager tabs

The file manager is divided into three tabs, and icons indicate where the files are saved.

- **All Files** – all content in the phone memory and on a memory card.
- **On Memory Stick** – all content on a memory card.
- **In Phone** – all content in the phone memory.

To view information about files

- 1 From standby select **Menu > File Manager**.
- 2 Scroll to a folder and select **Open**.
- 3 Scroll to a file and select **More > Information**.

To move a file in the file manager

- 1 From standby select **Menu > File Manager**.
- 2 Scroll to a folder and select **Open**.
- 3 Scroll to a file and select **More > Manage File > Move**.
- 4 Select an option.

To select more than one file in a folder

- 1 From standby select **Menu > File Manager**.
- 2 Scroll to a folder and select **Open**.
- 3 Select **More > Mark > Mark Several**.
- 4 Select **Mark** to mark the files.

To delete a file from the file manager

- 1 From standby select **Menu > File Manager**.
- 2 Find the file and press **(C)**.

Phone Language

You can select a language to use in your phone.

To change the phone language

- 1 From standby select **Menu > Settings > the General tab > Language > Phone Language**.
- 2 Select an option.

Entering Text

You can use multitap text input or T9™ Text Input **T9** to enter text. The T9 Text Input method uses a built-in dictionary.

To change text input method

- When you enter text, press and hold down ***a/A**.

To shift between capitals and lower-case letters

- When you enter text, press ***a/A**.

To enter numbers

- When you enter text, press and hold down **0+** – **9**.

To enter periods and commas

- When you enter text, press **123=**.

To enter text using T9™ Text Input

- 1 From standby select, for example, **Menu > Messaging > Write New > Text Message**.
- 2 If **T9** is not displayed, press and hold down ***a/A** to change to T9 Text Input.
- 3 Press each key only once, even if the letter you want is not the first letter on the key. For example, if you want to write the word “Jane”, press **5**, **2**, **6**, **3**. Write the whole word before looking at the suggestions.
- 4 Use **↶** or **↷** to view suggestions.
- 5 Press **#↶↷** to accept a suggestion.

To enter text using multitap

- 1 From standby select, for example, **Menu > Messaging > Write New > Text Message**.
- 2 If **T9** is displayed, press and hold down ***a/A** to change to multitap text input.
- 3 Press **2** – **9** repeatedly until the desired letter appears.
- 4 When a word is written, press **#↶↷** to add a space.

To add words to the built-in dictionary

- 1 When you enter text using T9 Text Input, select **More > Spell Word**.
- 2 Write the word using multitap input and select **Insert**.

Walkman® and Music

Listen to music, audio books and podcasts. Use *Sony Ericsson Media Manager* to transfer content to your phone.

Transferring Content to and from a Computer

Using a USB cable and *Sony Ericsson Media Manager*, you can transfer content from CDs, your computer or the phone.

 *Sony Ericsson Media Manager software is included on the CD that comes with your phone and available for download at www.sonyericsson.com/support.*

Required operating systems

You need one of these operating systems on your computer to use the *software included on the CD*:



- Microsoft® Windows Vista™ (32 bit and 64 bit versions of: Ultimate, Enterprise, Business, Home Premium, Home Basic)
- Microsoft Windows® XP (Pro or Home), Service Pack 2 or higher

To install Media Manager

- 1 Turn on your computer and insert the CD. The CD starts automatically and the installation window opens.
- 2 Select a language and click OK.
- 3 Click *Install Sony Ericsson Media Manager* and follow the instructions.

To transfer content using Media Manager

- 1 Connect the phone to a computer with the USB cable that came with the phone.
 - 2 Computer: *Start/Programs/Sony Ericsson/Media Manager*. Wait for Media Manager to start.
 - 3 Phone: Select **File Transfer**. The phone turns off and prepares to transfer files.
-  *Do not remove the USB cable from your phone or computer during transfer, as this may corrupt the memory card or the phone memory.*
- 4 Computer: Wait until the phone appears in Media Manager.
 - 5 Move files between your phone and the computer in Media Manager.
 - 6 For safe disconnection of the USB cable in file transfer mode, right-click the removable disk icon in *Windows Explorer* and select *Eject*.

 For details on transferring music, refer to *Media Manager Help*. Click  in the top-right corner of the *Media Manager* window.

Stereo portable handsfree



To use the handsfree

- Connect the portable handsfree. Music stops when you receive a call and resumes when the call has ended.

Walkman® Player

To play music

- 1 From standby select **Menu** > **WALKMAN**.
- 2 Scroll to a title and select **Play**.

Walkman® player controls

You can control the Walkman® player with the phone open.



To stop playing music

- Press .



To resume playing music

- From standby press  and select **Play**.

To fast forward and rewind

- When you listen to music, press and hold down  or .

To move between tracks

- When you listen to music, press  or .

To access the music files

- Press  to switch between the Walkman® player and the music files.

To change the volume

- Press  or .

Music keys

The music keys are used to control the Walkman® player with the flip closed.

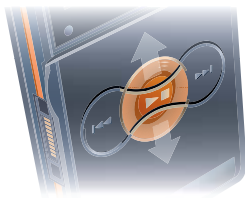



To start playing music

- Press .

To stop playing music

- Press .



To fast forward and rewind

When you listen to music, press and hold down  or .

To access the tracks currently playing

- When you listen to music, press  up or down.

To move between tracks

- When you listen to music, press  or .

Music key lock

When the phone is closed you can use the music key lock to lock and unlock the music keys.

To lock and unlock the music keys

- Slide the music key lock switch.

Browsing files

Music files are saved and categorized.

- [Artists](#) – list tracks you have transferred using Media Manager.
- [Albums](#) – list tracks by album.
- [Tracks](#) – list all music tracks in your phone and on a memory card.
- [Playlists](#) – your own lists of tracks.

Playlists

You can create playlists to organize files in [File Manager](#). Files can be added to more than one playlist.

Deleting a playlist, or a file from a playlist, does not delete the file from the memory, just the reference to the file.

To create a playlist

- 1 From standby select [Menu](#) > [WALKMAN](#) > [More](#) > [My Music](#).
- 2 Scroll to [Playlists](#) and select [Open](#).
- 3 Scroll to [New Playlist](#) and select [Add](#).
- 4 Enter a name and select [OK](#).
- 5 Scroll to a track and select [Mark](#).
- 6 Select [Add](#) to add the track to the playlist.

To add files to a playlist

- 1 From standby select [Menu](#) > [WALKMAN](#) > [More](#) > [My Music](#).
- 2 Scroll to [Playlists](#) and select [Open](#).
- 3 Scroll to the playlist and select [Open](#).
- 4 Select [More](#) > [Add Media](#).
- 5 Scroll to a track and select [Mark](#).
- 6 Select [Add](#) to add the track to the playlist.

To remove tracks from a playlist

- 1 From standby select **Menu**
> **WALKMAN** > **More** > **My Music**.
- 2 Scroll to a playlist and select **Open**.
- 3 Scroll to the track and press **C**.

To delete a playlist

- 1 From standby select **Menu**
> **WALKMAN** > **More** > **My Music**
> **Playlists**.
- 2 Scroll to a playlist and press **C**.

To view information about a track

- Scroll to a track and select **More**
> **Information**.

Sending and receiving music

You can send and receive music in a picture message, an email or using Bluetooth.

To send music

- 1 From standby select **Menu**
> **WALKMAN**.
- 2 Scroll to a title and select **More** > **File**
> **Send**.
- 3 Select a transfer method.

- ! *Make sure the receiving device supports the transfer method you select.*

To receive music

- Follow the instructions that appear.

Music key lock

When the phone is closed you can use the music key lock to lock and unlock the music keys.

To lock and unlock the music keys

- Slide the music key lock switch.



PlayNow™

Connect to PlayNow™ to download ringtones, games, music themes and wallpaper. You can preview or listen to content before you purchase and download it to your phone.



- ! *This service is not available in all countries. Contact your network operator for more information.*

Before you use PlayNow™

You must have the required Internet connection settings in your phone. See *Settings* on page 46.

To listen to PlayNow™ music

- 1 From standby select **Menu**
> **PlayNow™**.
- 2 Scroll the PlayNow™ Web site and follow the instructions to preview and purchase content.

Downloading from PlayNow™

The price appears when you select to download and save a music file. Your phone bill or prepay card is debited when a purchase is accepted.

To download a music file

- 1 When you have listened to a music file preview, you can agree to accept the conditions.
- 2 Select **Yes** to download.

TrackID™

TrackID™ is a music recognition service. You can search for song titles, artists and album names.

To search for song information

- 1 When you hear a song through a loudspeaker, from standby select **Menu > Entertainment > TrackID™ > Start**.
- 2 When the radio is playing select **More > TrackID™**.

Calling

Making and Receiving Calls

You need to turn on your phone and be within range of a network.

- ! *Do not cover the bottom of your phone when it is in use, as this affects call quality.*

To make a call

- 1 From standby enter a phone number (with international country code and area code, if applicable).
- 2 Select **Call**.

- 💡 *You can call numbers from the contacts and call list. See **Contacts** on page 23, and **Call List** on page 26.*

To make international calls

- 1 From standby press and hold down **(0+)** until a “+” sign appears.
- 2 Enter the country code, area code (without the first zero) and phone number.
- 3 Select **Call**.

To re-dial a number

- When **Retry?** appears select **Yes**.

- ⚠ *Do not hold your phone to your ear when waiting. When the call connects, your phone gives a loud signal.*

To answer a call

- Select [Answer](#).
- Open the flip.



To reject a call

- Select [Busy](#).

To change the ear speaker volume during a call

- Press  or .

To mute the microphone during a call

- 1 Press and hold down .
- 2 Press and hold down  again to resume.

To turn the loudspeaker on during a call

- Select [More](#) > [Turn On Speaker](#).

 *Do not hold your phone to your ear when using the loudspeaker. This could damage your hearing.*

Emergency Calls

Your phone supports international emergency numbers, for example, 112 and 911. These numbers can normally be used to make emergency calls in any country, with or without the SIM card inserted, if a network is within range.

 *In some countries, other emergency numbers may also be promoted. Your network operator may therefore have saved additional local emergency numbers on the SIM card.*

To make an emergency call

- From standby enter 112 (the international emergency number) and select [Call](#).

To view your local emergency numbers

- 1 From standby select [Menu](#) > [Contacts](#).
- 2 Scroll to [New Contact](#).
- 3 Select [Options](#) > [Special Numbers](#) > [Emergency Nos.](#)

Contacts

You can save names, phone numbers and personal information in [Contacts](#). Information can be saved in the phone memory or on the SIM card.

Default contact

You can choose which contact information – [Phone Contacts](#) or [SIM Contacts](#) – is shown as default.

If [Phone Contacts](#) is selected as default, your contacts show all the information saved in [Contacts](#). If you select [SIM Contacts](#) as default, your contacts show names and numbers saved on the SIM card.

To select default contacts

- 1 From standby select [Menu](#) > [Contacts](#).
- 2 Scroll to [New Contact](#) and select [Options](#) > [Advanced](#) > [Default Contacts](#).
- 3 Select an option.

Phone contacts

Phone contacts can contain names, phone numbers and personal information. They are saved in the phone memory.

To add a phone contact

- 1 From standby select [Menu](#) > [Contacts](#).
- 2 Scroll to [New Contact](#) and select [Add](#).
- 3 Enter the name and select [OK](#).
- 4 Enter the number and select [OK](#).
- 5 Select a number option.
- 6 Scroll between tabs and select the fields to add information.
- 7 Select [Save](#).

To add an item to a phone contact

- 1 From standby select [Menu](#) > [Contacts](#).
- 2 Scroll to a contact and select [More](#) > [Edit Contact](#).
- 3 Scroll between the tabs and select [Add](#).
- 4 Select an option and an item to add.
- 5 Select [Save](#).

 If your subscription supports Calling Line Identification (CLI) service, you can assign personal ringtones to contacts.

To copy names and numbers to the SIM card

- 1 From standby select [Menu](#) > [Contacts](#).
- 2 Select [More](#) > [Options](#) > [Advanced](#) > [Copy to SIM](#).
- 3 Select an option.

 When you copy all contacts from your phone to the SIM card, all existing SIM card information is replaced.

To call a phone contact

- 1 From standby select [Menu](#) > [Contacts](#).
- 2 Scroll to a contact and select [Call](#).

 To go directly to a contact, from standby press [2](#) - [9](#). See [Speed Dial](#) on page 26.

To call a SIM contact from phone contacts

- 1 From standby select [Menu](#) > [Contacts](#) > [More](#) > [Options](#) > [SIM Contacts](#).
- 2 Scroll to a contact and select [Call](#).

To automatically save names and phone numbers on the SIM card

- 1 From standby select [Menu](#) > [Contacts](#).
- 2 Select [More](#) > [Options](#) > [Advanced](#) > [Auto Save on SIM](#).
- 3 Select an option.

SIM contacts

SIM contacts can contain names and numbers only. They are saved on the SIM card.

To add a SIM contact

- 1 From standby select [Menu > Contacts](#).
- 2 Scroll to [New Contact](#) and select [Add](#).
- 3 Enter the name and select [OK](#).
- 4 Enter the number and select [OK](#).
- 5 Select a number option and add more information, if available.
- 6 Select [Save](#).

To copy names and numbers to phone contacts

- 1 From standby select [Menu > Contacts](#).
- 2 Select [More > Options > Advanced > Copy from SIM](#).
- 3 Select an option.

To call a SIM contact

- 1 From standby select [Menu > Contacts](#).
- 2 Scroll to a contact and select [Call](#).

Deleting contacts

To delete a contact

- 1 From standby select [Menu > Contacts](#).
- 2 Scroll to a contact and press [C](#).

To delete all phone contacts

- 1 From standby select [Menu > Contacts](#).
- 2 Select [More > Options > Advanced > Delete all contacts](#).

Sending contacts

To send a contact

- 1 From standby select [Menu > Contacts](#).
- 2 Scroll to a contact and select [More > Send Contact](#).
- 3 Select a transfer method.

! *Make sure the receiving device supports the transfer method you select.*

Memory status

The number of contacts you can save in your phone or on the SIM card depends on available memory.

To view memory status

- 1 From standby select [Menu > Contacts](#).
- 2 Select [More > Options > Advanced > Memory Status](#).

To save contacts on a memory card

- 1 From standby select [Menu > Contacts](#).
- 2 Select [More > Options > Advanced > Back Up To M.S.](#)

Synchronizing contacts

Contacts can be synchronized with your computer and some Web applications. For more information, see *Synchronizing* on page 51.

Groups

You can create a group of phone numbers and email addresses to send messages to. See *Messaging* on page 31. You can also use groups (with phone numbers) when you create accepted callers lists. See *Accept Calls* on page 29.

To create a group of numbers and email addresses

- 1 From standby select **Menu** > **Contacts** > **Options** > **Groups** > **New Group**.
- 2 Enter a name for the group and select **Continue**.
- 3 Select **New** to find and select a contact phone number or email address.
- 4 Repeat step 3 to add more phone numbers or email addresses.
- 5 Select **Done**.

Call List

You can view information about most recent calls.

To call a number from the call list

- 1 From standby select **Calls** and scroll to a tab.
- 2 Scroll to a name or a number and select **Call**.

To add a call list number to contacts

- 1 From standby select **Calls** and scroll to a tab.
- 2 Scroll to the number and select **More** > **Save Number**.
- 3 Select **New Contact** to create a new contact or select an existing contact to add the number to.

To clear the call list

- From standby select **Calls** > the **All** tab > **More** > **Delete All**.

Speed Dial

Speed dialing lets you select nine contacts that you can dial quickly. The contacts can be saved in positions 1-9.

To add contacts to speed dial numbers

- 1 From standby select **Menu** > **Contacts**.
- 2 Select **Options** > **Speed Dial**.
- 3 Scroll to a position number and select **Add**.
- 4 Select a contact.

To speed dial

- From standby enter the position number and select **Call**.

Voicemail

If your subscription includes an answering service, callers can leave a voicemail message when you cannot answer a call.

To enter your voicemail number

- 1 From standby select **Menu** > **Messaging** > **Settings** > **Voicemail Number**.
- 2 Enter the number and select **OK**.

To call your voicemail service

- From standby press and hold down .

To edit your voicemail number

- 1 From standby select **Menu** > **Messaging** > **Settings** > **Voicemail Number**.
- 2 Edit the number and select **OK**.

Forwarding Calls

You can forward calls, for example, to an answering service.

- ! *When **Restrict Calls** is used, some forward call options are not available. See **Restricted Dialing** on page 29.*

Forward call options

Standard options are:

- **Always Forward** – forward all your calls
- **When Busy** – if a call is ongoing

- **Not Reachable** – if turned off or unreachable
- **No Reply** – if not answered in a specified time

To forward calls

- 1 From standby select **Menu** > **Settings** > the **Calls** tab > **Forward Calls**.
- 2 Scroll to a call type and forward option and select **Activate**.
- 3 Enter the number to forward calls to and select **OK**.

More than One Call

You can handle more than one call at the same time. For example, you can put an ongoing call on hold, while you make or answer a second call. You can also switch between the two calls. You cannot answer a third call without ending one of the first two calls.

Call waiting

When call waiting is used, you hear a beep if you receive a second call.

To activate call waiting

- From standby select **Menu** > **Settings** > the **Calls** tab > **Manage Calls** > **Call Waiting** > **Activate**.

To make a second call

- 1 During the call, select **More** > **Hold**. This puts the ongoing call on hold.
- 2 Enter the number to call and select **More** > **Call**.

To answer a second call

- During the call, select **Answer**. This puts the ongoing call on hold.

To reject a second call

- During the call, select **Busy** and continue with the ongoing call.

To end an ongoing call and answer a second call

- During the call, select **Replace Active Call**.



Handling Two Voice Calls

You can have calls ongoing and on hold at the same time.

To switch between two calls

- During the call, select **More** > **Switch**.

To join two calls

- During the call, select **More** > **Join Calls**.

To connect two calls

- During the call, select **More** > **Transfer Call**. You are disconnected from both calls.

To end an ongoing call and return to the call on hold

- Select **End Call** > **Yes**.

To end both calls

- Select **End Call** > **No**.

Receiving a third voice call

You cannot answer a third call without ending one of the first two calls or joining them into a conference call.



Conference Calls

With a conference call, you can have a joint conversation with up to five people.

To join the two calls

- During the call, select **More** > **Join Calls**.

To add a new participant

- 1 During the call, select **More** > **Hold**. This puts the joined calls on hold.
- 2 Select **More** > **Add Call**.
- 3 Enter the number to call and select **Call**.
- 4 Select **More** > **Join Calls** to add the new participant.
- 5 Repeat this task to add more participants.

To release a participant

- 1 Select **More** > **Release Party**.
- 2 Select the participant to release.

To have a private conversation

- 1 During the call, select [More](#) > [Talk to](#) and select the participant to talk to.
- 2 To resume the conference call, select [More](#) > [Join Calls](#).

 *If your subscription supports Alternate Line Service (ALS), you can make separate calls with different phone numbers.*

My Numbers

You can view, add and edit your own phone numbers.

To check your phone numbers

- 1 From standby select [Menu](#) > [Contacts](#) > [Options](#) > [Special Numbers](#) > [My Numbers](#).
- 2 Select an option.

Accept Calls

You can choose to receive calls from certain phone numbers only.

To add numbers to the accepted callers list

- 1 From standby select [Menu](#) > [Settings](#) > the [Calls](#) tab > [Manage Calls](#) > [Accept Calls](#) > [Only from List](#) > [New](#).
- 2 Scroll to a contact or select [Groups](#). See [Groups](#) on page 26.

To accept all calls

- From standby select [Menu](#) > [Settings](#) > the [Calls](#) tab > [Manage Calls](#) > [Accept Calls](#) > [All Callers](#).



Restricted Dialing

You can restrict outgoing and incoming calls. A password from your service provider is required.



If you forward incoming calls, you cannot use some restrict calls options.

Restrict calls options

Standard options are:

- [All Outgoing](#) – all outgoing calls
- [Outgoing Intl.](#) – all outgoing international calls
- [Outg Intl Roam](#) – all outgoing international calls except to your home country
- [All Incoming](#) – all incoming calls
- [Inc. Whn Roaming](#) – all incoming calls when you are abroad

To restrict calls

- 1 From standby select [Menu](#) > [Settings](#) > the [Calls](#) tab > [Manage Calls](#) > [Restrict Calls](#).
- 2 Select an option.
- 3 Enter your password and select [OK](#).



Fixed Dialing

Fixed dialing allows calls to be made only to certain numbers saved on the SIM card. The fixed numbers are protected by your PIN2.



When fixed dialing is used, you can still call the international emergency number, 112.

Partial numbers can be saved. For example, saving 0123456 allows calls to be made to all numbers starting with 0123456.



When fixed dialing is used, you cannot view or manage any phone numbers saved on the SIM card.

To use fixed dialing

- 1 From standby select **Menu > Contacts**.
- 2 Select **More > Options > Special Numbers > Fixed Dialing > Activate**.
- 3 Enter your PIN2 and select **OK**.
- 4 Select **OK** again to confirm.

To save a fixed number

- 1 From standby select **Menu > Contacts**.
- 2 Select **More > Options > Special Numbers > Fixed Dialing > Fixed Numbers > New Number**.
- 3 Enter the information and select **Save**.



Call Time and Cost

During a call, the duration of the call is shown. You can check the duration of your last call, outgoing calls and the total time of your calls.

To check the call time

- From standby select **Menu > Settings > the Calls tab > Time & Cost > Call Timers**.

Business Cards

To add your own business card

- 1 From standby select **Menu > Contacts**.
- 2 Select **More > Options > My Business Card**.
- 3 Scroll between tabs and select the fields to add information. To enter a symbol select **More > Add Symbol > Insert**.
- 4 Enter the information and select **Save**.

To send your business card

- 1 From standby select **Menu > Contacts**.
- 2 Select **More > Options > My Business Card > Send My Card**.
- 3 Select a transfer method.



Make sure the receiving device supports the transfer method you select.

Messaging

Text Messages

Text messages can contain simple pictures, sound effects, animations, and melodies.

Before you use messaging

You must have a service center number. The number is supplied by your service provider and is usually saved on the SIM card. If the number to your service center is not saved on your SIM card, you must enter the number yourself.

To enter a service center number

- 1 From standby select [Menu](#) > [Messaging](#) > [Settings](#) > [Text Message](#) > [Service Center](#). The number is shown if it is saved on the SIM card.
- 2 If there is no number shown, select [Edit](#) > [New ServiceCenter](#) and enter the number, including the international “+” sign and country code.
- 3 Select [Save](#).

Sending messages

For information about entering letters, see *Entering Text* on page 17.

To write and send a text message

- 1 From standby select [Menu](#) > [Messaging](#) > [Write New](#) > [Text Message](#).
- 2 Write the message and select [Continue](#) > [Contacts Lookup](#).
- 3 Select a recipient and select [Send](#).

! If you send a text message to a group, you will be charged for each member. See *Groups* on page 26.

To select more than one text message

- 1 From standby select [Menu](#) > [Messaging](#) and select a folder.
- 2 Scroll to a message and select [More](#) > [Mark Several](#).
- 3 Select [Mark](#) to mark the messages.

To add an item to a text message

- 1 When you write the message, select [More](#) > [Add Item](#).
- 2 Select an option and then an item.

Receiving text messages

You are notified when you receive a message. Received messages are saved in the inbox.

To view a text message from the inbox

- 1 From standby select [Menu](#) > [Messaging](#) > [Inbox](#).
- 2 Scroll to the message and select [View](#).

To close a text message

- Press .

To call a number in a text message

- When you view the message, scroll to the phone number and select **Call**.

Saving and deleting text messages

Received text messages are saved in the phone memory. When the phone memory is full, you can delete messages or move them to the SIM card.

To save a text message on the SIM card

- 1 From standby select **Menu** > **Messaging** and select a folder.
- 2 Scroll to the message and select **More** > **Save Message** > **Saved Messages**.

To save an item in a text message

- 1 When you view the message, select the item.
- 2 Select **More** > **Use**.
- 3 Select an option.

To delete a text message

- 1 From standby select **Menu** > **Messaging** and select a folder.
- 2 Scroll to the message and press .

Picture Messages

Picture messages can contain text, pictures, slides, sound recordings, signatures and attachments. You can send picture messages to a phone or an email address.

Before you use picture messaging

You must set an Internet profile and the address of your message server. If no Internet profile or message server exists, you can receive all the settings automatically from your network operator or at www.sonyericsson.com/support.

To select an Internet profile

- 1 From standby select **Menu** > **Messaging** > **Settings** > **Picture Message** > **MMS Profile**.
- 2 Select a profile.

To set the message server address

- 1 From standby select **Menu** > **Messaging** > **Settings** > **Picture Message** > **MMS Profile**.
- 2 Scroll to a profile and select **More** > **Edit** > **Message Server**.
- 3 Select **Edit** and enter the address.

Sending messages

For information about entering letters, see *Entering Text* on page 17.

To create and send a picture message

- 1 From standby select **Menu** > **Messaging** > **Write New** > **Picture Message**.
- 2 Enter the text and press  to add items to the message.
- 3 Select **Continue** > **Contacts Lookup**.
- 4 Select a recipient and select **Send**.

Receiving picture messages

You can select how to download your picture messages. Standard options when you download picture messages are:

- **Always** – automatic download.
- **Ask in Roaming** – ask to download when not in home network.
- **Not in Roaming** – do not download when not in home network.
- **Always Ask** – ask to download.
- **Off** – new messages appear in the **Inbox**.

To set automatic download

- 1 From standby select **Menu** > **Messaging** > **Settings** > **Picture Message** > **Auto Download**.
- 2 Select an option.

To view a picture message from the inbox

- 1 From standby select **Menu** > **Messaging** > **Inbox**.
- 2 Scroll to the message and select **View**.

To close a picture message

- Press .

To save an item in a picture message

- When you view a picture message select **More** > **Save Items** and select an item.

To delete a message

- 1 From standby select **Menu** > **Messaging** and select a folder.
- 2 Scroll to the message and press .

Message options

You can set standard options for all messages or choose specific settings each time you send a message.

To set text message options

- 1 From standby select **Menu** > **Messaging** > **Settings** > **Text Message**.
- 2 Scroll to an option and select **Edit**.

To set picture message options

- 1 From standby select **Menu** > **Messaging** > **Settings** > **Picture Message**.
- 2 Scroll to an option and select **Edit**.

Send options

You can request a delivery report, a read report, and set a priority for a specific message. You can also add more recipients to the message.

To set send options

- 1 When the message is ready and a recipient is selected, select **More** > **Advanced**.
- 2 Scroll to an option and select **Edit**.

Templates

If you often use the same phrases and pictures in a message, you can save the message as a template.

To use a text message template

- 1 From standby select **Menu** > **Messaging** > **Templates**.
- 2 Scroll to a template and select **Use** > **Text Message**.
- 3 Add text and select **Continue** and select a recipient.

To use a picture message template

- 1 From standby select **Menu** > **Messaging** > **Templates**.
- 2 Scroll to a template and select **Use**.
- 3 When the message is ready, select **Continue** and select a recipient.

To add a text message template

- 1 From standby select **Menu** > **Messaging** > **Templates** > **New Template** > **Text**.
- 2 Insert text or select **More** to add items. Select **OK**.
- 3 Enter a title and select **OK**.

To add a picture message template

- 1 From standby select **Menu** > **Messaging** > **Templates** > **New Template** > **Picture Msg**.
- 2 Enter the text and press  to add items to the message.
- 3 Select **Save**, enter a title and select **OK**.

To edit a template

- 1 From standby select **Menu** > **Messaging** > **Templates**.
- 2 Scroll to a template and select **More** > **Edit Template** > **Save**.

To save a message as a template

- 1 From standby select **Menu** > **Messaging** > **Inbox**.
- 2 Scroll to the message and select **More** > **Save Message** > **Templates**.



Voice Messages

You can send and receive a sound recording as a voice message.



The sender and recipient must have a subscription supporting picture messaging.

To record and send a voice message

- 1 From standby select **Menu** > **Messaging** > **Write New** > **Voice Message**.
- 2 Record the message and select **Stop** > **Send** > **Contacts Lookup**.
- 3 Select a recipient and select **Send**.

Email

You can use standard email functions and your computer email address in your phone.

Before you use email

Email settings must be entered in your phone. You can have these settings sent directly to your phone from the Sony Ericsson support site, or you can enter them manually.

Email settings using Internet

You can receive settings at www.sonyericsson.com/support.

Entering email settings manually

You can also enter the email settings manually. To do this, you need to ask your email provider for the settings information:

Settings types	Examples
Connection Type	POP3 or IMAP4
Email Address	joe.smith@ example.com
Incoming Server	mail.example.com
Username	jsmith
Password	zX123
Outgoing Server	mail.example.com

An email provider could be the company that supplied your email address, for example, your IT administrator at work or an Internet provider.

You may find settings information in your computer email program settings, or in a document from your email provider.

- ! *There are many different email providers. Their terminology and required information may differ. Not all service providers allow email access.*

To enter email settings



- 1 From standby select [Menu](#) > [Messaging](#) > [Email](#) > [Settings](#).
- 2 Enter the settings.

Help appears as you enter settings.

-  *For more information, contact your email provider or go to www.sonyericsson.com/support.*

To write and send an email message

- 1 From standby select [Menu](#) > [Messaging](#) > [Email](#) > [Write New](#).
- 2 Select [Add](#) > [Enter Email Addr.](#) Enter the email address and select [OK](#).
- 3 To enter more recipients, select [Edit](#). Scroll to an option and select [Add](#) > [Enter Email Addr.](#) Enter the email address and select [OK](#). When you are ready, select [Done](#).

- 4 Press  to scroll to **Subject:**. Select **Edit** and enter a subject.
- 5 Press  to scroll to **Text:**. Select **Edit** and enter the text.
- 6 Press  to scroll to **Attachments:**. Select **Add** and select a file to attach.
- 7 Select **Continue** > **Send**.

To receive and read an email message

- 1 From standby select **Menu** > **Messaging** > **Email** > **Inbox** > **Snd&Rec**.
- 2 Scroll to the message and select **View**.

To save an email message

- 1 From standby select **Menu** > **Messaging** > **Email** > **Inbox**.
- 2 Scroll to the message and select **More** > **Save Message** > **Saved Email**.

To reply to an email message

- 1 From standby select **Menu** > **Messaging** > **Email** > **Inbox**.
- 2 Scroll to the message and select **More** > **Reply**.
- 3 Write the reply and select **OK**.
- 4 Select **Continue** > **Send**.

To view an attachment in an email message

- When you view the message, select **More** > **Attachments** > **View**.

To save an attachment in an email message

- When you view the message, select **More** > **Attachments** > **View** > **Save**.

Active email account

If you have several email accounts, you can change which one is active.

To change the active email account

- 1 From standby select **Menu** > **Messaging** > **Email** > **Settings**.
- 2 Select an account.

To delete an email message (POP3)

- 1 From standby select **Menu** > **Messaging** > **Email** > **Inbox**.
- 2 Scroll to the message and select **More** > **Mrk for Deletion** > **Yes**.

- ! *Marked messages will be deleted when you next connect to your server.*

To delete an email message (IMAP4)

- 1 From standby select **Menu** > **Messaging** > **Email** > **Inbox**.
- 2 Scroll to the message and select **More** > **Mrk for Deletion** > **Yes**.
- 3 Select **More** > **Clear Inbox**.

- ! *Marked messages will be deleted in the phone and on the server.*

Push email

You can receive notification in your phone from your email server that you have new email.

To turn on push email notification

- 1 From standby select [Menu](#) > [Messaging](#) > [Email](#) > [Settings](#).
- 2 Scroll to an account to edit and select [More](#) > [Edit Account](#) > [Advanced Settings](#) > [Push Email](#).
- 3 Select an option.

My Friends

You can connect and log in to the My friends server to communicate online with chat messages.

Before you use My friends

If no settings exist in your phone, you need to enter server settings. Standard settings information supplied by your service provider is:

- username
- password
- server address
- Internet profile

To enter My friends server settings

- 1 From standby select [Menu](#) > [Messaging](#) > [My Friends](#) > [Configure](#).
- 2 Select [Add](#) and enter the settings.

To edit My friends settings

- 1 From standby select [Menu](#) > [Messaging](#) > [My Friends](#).
- 2 Select [More](#) > [Settings](#).
- 3 Scroll to the setting and press [Select](#).

To log in to the My friends server

- From standby select [Menu](#) > [Messaging](#) > [My Friends](#) > [Log In](#).

To log out of the My friends server

- Select [More](#) > [Log Out](#).

To add a chat contact

- 1 From standby select [Menu](#) > [Messaging](#) > [My Friends](#) > the [Contacts](#) tab.
- 2 Select [More](#) > [Add Contact](#).

To send a chat message

- 1 From standby select [Menu](#) > [Messaging](#) > [My Friends](#) > the [Contacts](#) tab.
- 2 Scroll to a contact and select [Chat](#).
- 3 Write the message and select [Send](#).

Status

You can show your status, for example, [Happy](#) or [Busy](#), to your contacts only. You can also show your status to all users on the My friends server.

To show my status

- 1 From standby select [Menu](#) > [Messaging](#) > [My Friends](#) > [More](#) > [Settings](#) > [Show My Status](#).
- 2 Select an option.

To update your own status

- 1 From standby select **Menu > Messaging > My Friends > the My Status tab.**
- 2 Scroll between tabs and select the fields to add information.

Chat group

A chat group can be started by your service provider, by an individual My friends user or by yourself. You can save chat groups by saving a chat invitation or by searching for a specific chat group.

To create a chat group

- 1 From standby select **Menu > Messaging > My Friends > the Chat Groups tab.**
- 2 Select **More > Add Chat Group > New Chat Group.**
- 3 Select who to invite from your contacts list and select **Continue.**
- 4 Enter a short invitation text and select **Continue > Send.**

To add a chat group

- 1 From standby select **Menu > Messaging > My Friends > the Chat Groups tab > More > Add Chat Group.**
- 2 Select an option.

- ! *Conversation history is saved between log out and when you log in again to let you return to chat messages from previous conversations.*

To save a conversation

- 1 From standby select **Menu > Messaging > My Friends > the Conversations tab.**
- 2 Enter a conversation.
- 3 Select **More > Advanced > Save Conv.**

To view a saved conversation

- 1 From standby select **Menu > Messaging > My Friends > the Conversations tab.**
- 2 Select **More > Saved Conv.**



Area and Cell Information

Area and cell information are text messages, for example, local traffic reports that are sent to subscribers within a certain network area.

- ! *Contact your service provider for more information.*

To turn area information on

- 1 From standby select **Menu > Messaging > Settings > Area Info.**
- 2 Scroll to **Reception** and select **Edit > On.**

Imaging

Camera

You can take pictures to view, save or send.





- 1 Adjust brightness
- 2 Zoom in
- 3 Take pictures
- 4 Zoom out

To activate the camera

- From standby select [Menu](#) > [Camera](#).

To take a picture

- 1 Activate the camera.
- 2 Select [Capture](#) to take a picture.
- 3 Press  to take another picture.
- 4 Press and hold down  to stop the camera.

To use zoom

Your phone has a digital zoom. Depending on the selected picture size, the following zoom levels are available:

- Picture size 1 MP - no zoom
- Picture size VGA (640x480) - 2x zoom
- Picture size QVGA (320x240) - 4x zoom

To use the zoom

- Press  or .

To adjust brightness

- Press  or .

To save and delete pictures

- 1 From standby select [Menu](#) > [File Manager](#) > [Camera Album](#).
- 2 Scroll to an item and select [More](#).

To view pictures

- 1 From standby select [Menu](#) > [File Manager](#) > [Camera Album](#).
- 2 Scroll to an item and select [View](#).

To search camera pictures by time line

- 1 From standby select [Menu](#) > [File Manager](#) > [Camera Album](#).
- 2 To browse camera pictures sorted by date, select [More](#) > [Timeline View](#).

To delete pictures

- 1 From standby select [Menu](#) > [File Manager](#) > [Camera Album](#).
- 2 Scroll to an item and press .

Camera settings

You can select different settings before you take a picture.





To view settings

- When the camera is activated, select [More](#).

To view information about settings

- Scroll to a setting and select [Info](#).

Camera shortcuts

Key	Shortcut
	Shoot Mode
	Picture Size
	Night Mode
	Key guide

Transferring Pictures

Transfer to and from your computer

You can use Bluetooth technology and picture messages to transfer pictures to your computer. You can also use the USB cable to drag and drop camera pictures. See *Bluetooth™ Wireless Technology* and *Using the USB Cable* on page 50.

You can view, enhance and organize your pictures on your computer by installing *Adobe™ Photoshop™ Album Starter Edition* or the *Sony Ericsson Media Manager*. These are included on the CD that comes with your phone and are available for download at www.sonyericsson.com/support.

Picture blog

A picture blog is a personal Web page. If your subscription supports this service, you can send pictures to a blog.

 *Web services may require a separate license agreement between you and the service provider. Additional regulations and/or charges may apply. Contact your service provider.*

To send camera pictures to a blog

- 1 From standby select [Menu](#) > [File Manager](#) > [Camera Album](#).
- 2 Scroll to a picture and select [More](#) > [Send](#) > [To Blog](#).
- 3 Add title and text.
- 4 Select [OK](#) > [Publish](#).

To go to a blog address from contacts

- 1 From standby select [Menu](#) > [Contacts](#).
- 2 Scroll to a contact.
- 3 Scroll to a Web address and select [Go To](#).

Pictures

You can view, add, copy or delete pictures in [File Manager](#). File types supported are, for example, GIF, JPEG, BMP and PNG.

Using pictures

You can add a picture to a contact, use it during phone startup, as a wallpaper in standby or as a screen saver.

To view pictures

- 1 From standby select [Menu](#) > [File Manager](#) > [Pictures](#).
- 2 Scroll to a picture and select [View](#).

To use pictures

- 1 From standby select [Menu](#) > [File Manager](#) > [Pictures](#).
- 2 Scroll to a picture and select [More](#) > [Use As](#).
- 3 Select an option.

To view pictures in a slide show

- 1 From standby select [Menu](#) > [File Manager](#) > [Pictures](#).
- 2 Scroll to a picture and select [View](#) > [More](#) > [Slide Show](#).

Sending and receiving

You can send and receive pictures as a picture message, an email or using Bluetooth.

To send a picture

- 1 From standby select [Menu](#) > [File Manager](#) > [Pictures](#).
- 2 Scroll to a picture and select [More](#) > [Send](#).
- 3 Select a transfer method.

- ! *Make sure the receiving device supports the transfer method you select.*

To receive a picture

- Follow the instructions that appear.

Entertainment



Radio

- ! Do not use your phone as a radio in places where this is prohibited.

To listen to the radio

- 1 Connect the handsfree to the phone.
- 2 From standby select **Menu > Radio**.

To change the volume



- When the radio is playing, press  or .



To automatically search for radio channels

- When the radio is playing, select **Search**.



- 💡 You can also press  to automatically search for radio channels.

To manually search for radio channels

- When the radio is playing, press  or .

- 💡 You can also press  or  to search for radio channels.

To search for preset channels

- When the radio is playing, press  or .

- 💡 Press  up or down to search for preset channels.

Saving radio channels

You can save up to 20 preset channels.



To save radio channels

- 1 From standby select **Menu > Radio**.
- 2 Select **Search** to find a radio channel.
- 3 Select **More > Save**.
- 4 Scroll to a position and select **Insert**.



To select saved radio channels

- 1 From standby select **Menu > Radio > More > Channels**.
- 2 Select a radio channel.

To save radio channels in positions 1 to 10

- When you have found a radio channel, press and hold down  - .

To select radio channels saved in positions 1 to 10

- When the radio is playing, press  - .

To view radio options



- When the radio is playing, select **More**.

Ringtones and Melodies

To set a ringtone

- 1 From standby select **Menu > Settings > the Sounds & Alerts tab > Ringtone**.
- 2 Select an option.

To set the ringtone volume

- 1 From standby select [Menu](#) > [Settings](#) > the [Sounds & Alerts](#) tab > [Ring Volume](#).
- 2 Press  or  to change the volume.
- 3 Select [Save](#).

To turn the ringtone off

- From standby press and hold down .
All signals except the alarm signal are affected.

To set the vibrating alert

- 1 From standby select [Menu](#) > [Settings](#) > the [Sounds & Alerts](#) tab > [Vibrating Alert](#).
- 2 Select an option.

To send a ringtone

- 1 From standby select [Menu](#) > [File Manager](#) > [Music](#) > [Ringtones](#).
- 2 Scroll to a ringtone and select [More](#) > [Send](#).
- 3 Select a transfer method.

- ! *Make sure the receiving device supports the transfer method you select.*

To receive a ringtone

- Follow the instructions that appear.

- ! *You are not allowed to exchange some copyright-protected material. A protected file has a key symbol.*

MusicDJ™

You can compose and edit your own melodies to use as ringtones. A melody consists of four types of tracks – [Drums](#), [Basses](#), [Chords](#), and [Accents](#). A track contains a number of music blocks. The blocks consist of pre-arranged sounds with different characteristics. The blocks are grouped into [Intro](#), [Verse](#), [Chorus](#), and [Break](#). You compose a melody by adding music blocks to the tracks.

To compose a melody

- 1 From standby select [Menu](#) > [Entertainment](#) > [MusicDJ™](#).
- 2 Select to [Insert](#), [Copy](#) or [Paste](#) blocks.
- 3 Use , ,  or  to scroll between the blocks.
- 4 Select [More](#) > [Save Melody](#).

To send a melody

- 1 From standby select [Menu](#) > [File Manager](#).
- 2 Scroll to [Music](#) and select [Open](#).
- 3 Scroll to a melody and select [More](#) > [Send](#).
- 4 Select a transfer method.

- ! *Make sure the receiving device supports the transfer method you select.*

To receive a melody

- Follow the instructions that appear.

- ! *You cannot send a polyphonic melody or MP3 file in a text message.*

Sound Recorder

You can record a voice memo. Recorded sounds can also be set as ringtones.

To record a sound

- From standby select [Menu](#) > [Entertainment](#) > [Record Sound](#).

To listen to a recording

- 1 From standby select [Menu](#) > [File Manager](#) > [Music](#).
- 2 Scroll to a recording and [Play](#).

Video Player

To play videos

- 1 From standby select [Menu](#) > [Entertainment](#) > [Video Player](#).
- 2 Scroll to a title and select [Play](#).

Video controls



To stop playing videos

- Press .



To resume playing videos

- Press .

To go to the next or previous clip

- When playing video clips, press  or .

To fast forward or rewind

- When playing video clips, press and hold down  or .

To change the volume

- Press  or .

Games

Your phone contains preloaded games. You can also download games. Help texts are available for most games.

To start a game

- 1 From standby select [Menu](#) > [Entertainment](#) > [Games](#).
- 2 Select game.

To end a game

- Press and hold down .

Applications

Before you use Java™ applications If settings are not already entered in your phone, see *Settings* on page 46.

You can download and run Java applications. You can also view information or set different permissions.

To select a Java application

- 1 From standby select [Menu > File Manager > Applications](#).
- 2 Select an application.

To view information about a Java application

- 1 From standby select [Menu > File Manager > Applications](#).
- 2 Scroll to an application and select [More > Information](#).

To set permissions for a Java application

- 1 From standby select [Menu > File Manager > Applications](#).
- 2 Scroll to an application and select [More > Permissions](#).

To set the screen size for a Java application

- 1 From standby select [Menu > File Manager > Applications](#).
- 2 Scroll to an application and select [More > Screen Size](#).
- 3 Select an option.

Internet profiles for Java applications

Some Java applications need to connect to the Internet to receive information.

To select an Internet profile for Java applications

- 1 From standby select [Menu > Settings > the Connectivity tab > Internet Settings > Settings for Java](#).
- 2 Select an option.

Connectivity

Settings

Before you use Internet, PlayNow™, My friends, Java, remote synchronization, picture messaging, email and picture blog you need to have settings in your phone.

If settings are not already entered, make sure your phone supports data transfer. You can download settings using the setup wizard or from www.sonyericsson.com/support.

To download settings using the Setup wizard

- 1 From standby select [Menu](#) > [Settings](#) > the [General](#) tab > [Setup Wizard](#) > [Settings Download](#).
- 2 Follow the instructions on the screen.

To download settings using a computer

- 1 Go to www.sonyericsson.com/support.
- 2 Follow the instructions on the screen.

Using Internet

You can use the Internet to access online services.

- ! *If your connections to the Internet do not work, see [Settings on page 46](#), or contact your operator.*

To start browsing

- From standby select [Menu](#) > [Internet](#).

To exit the browser

- When you browse the Internet, select [More](#) > [Exit Browser](#).

To view options

- When you browse the Internet, select [More](#).

When you browse the Internet

You can make a call or send a link when you browse the Internet.

To make a call

- When you browse the Internet, select [More](#) > [Tools](#) > [Make a Call](#).

To send a link

- 1 When you browse the Internet, select [More](#) > [Tools](#) > [Send Link](#).
- 2 Select an option.

Using bookmarks

You can create and edit bookmarks as quick links to your favorite Web pages.

To create a bookmark

- 1 From standby select [Menu](#) > [Internet](#) > [More](#) > [Go to](#) > [Bookmarks](#).
- 2 Scroll to [New Bookmark](#) and select [Add](#).
- 3 Enter the information and select [Save](#).

To select a bookmark













- 1 From standby select **Menu** > **Internet** > **More** > **Go to** > **Bookmarks**.
- 2 Scroll to a bookmark and select **Go To**.

Internet keypad shortcuts

You can use the keypad to go directly to an Internet browser function.

To select Internet keypad shortcuts

- From standby select **Menu** > **Internet** > **More** > **Options** > the **Browsing** tab > **Keypad Mode** > **Shortcuts**.

Key	Shortcut
 1	Bookmarks
 2	Enter Address
 3	Search Internet
 4	History
 5	Refresh Page
 6	Forward
 7	Page up
 8	Page down
 9	Full Screen or Normal Screen.
 0 +	Zoom
 # ... 	Shortcuts

Downloading

You can download files, for example, pictures, themes, games and ringtones from Web pages.

To download from a Web page

- 1 When you browse the Internet, select a file to download.
- 2 Follow the instructions on the screen.

Internet profiles

You can select another Internet profile if you have more than one.

To select an Internet profile for the Internet browser

- 1 From standby select **Menu** > **Settings** > the **Connectivity** tab > **Internet Settings** > **Internet Profiles**.
- 2 Select an option.

Internet security and certificates

Your phone supports secure browsing. Certain Internet services, such as banking, require certificates in your phone. Your phone may already contain certificates when you buy it or you can download new certificates.

To view certificates in the phone

- From standby select **Menu** > **Settings** > the **General** tab > **Security** > **Certificates**.

RSS Reader

You can receive frequently updated content, such as news headlines, as feeds, using Really Simple Syndication (RSS).

To add new feeds for a Web page

- When you browse the Internet, select [More > RSS Feeds](#).

To create a new feed

- 1 From standby select [Menu > Messaging > RSS Reader > More > New Feed](#).
- 2 Enter the RSS specific Web address (for example http://rss.cnn.com/rss/cnn_topstories.rss) and select [Go To](#).

To set and use RSS reader options

- 1 From standby select [Menu > Messaging > RSS Reader > More](#).
- 2 Select an option.

Bluetooth™ Wireless Technology

The Bluetooth function makes wireless connection to other Bluetooth devices possible. You can, for example:

- Connect to handsfree devices.
- Connect to stereo headsets.
- Connect to more than one device at the same time.

- Connect to computers and access the Internet.
- Synchronize information with computers.
- Use media viewer accessories.
- Exchange items and play multiplayer games.

- ! *We recommend a range within 33 feet (10 meters), with no solid objects in between, for Bluetooth communication.*

Before you use Bluetooth wireless technology

You must turn on the Bluetooth function to communicate with other devices. You must also pair your phone with other Bluetooth devices.

To turn the Bluetooth function on

- From standby select [Menu > Settings > the Connectivity tab > Bluetooth > Turn On](#).
- ! *Make sure that the device you want to pair your phone with has the Bluetooth function activated and is made visible.*

To pair the phone with a device

- 1 From standby select [Menu > Settings > the Connectivity tab > Bluetooth > My Devices > New Device](#) to search for available devices.
- 2 Select a device.
- 3 Enter a passcode, if required.

To allow connection to the phone

- 1 From standby select [Menu > Settings > the Connectivity tab > Bluetooth > My Devices](#).
- 2 Select a device from the list.
- 3 Select [More > Allow Connection](#).

To pair the phone with a Bluetooth handsfree for the first time

- 1 From standby select [Menu > Settings > the Connectivity tab > Bluetooth > Handsfree](#).
- 2 Select [Yes](#).
- 3 Enter a passcode, if required.

To pair the phone with more than one Bluetooth handsfree

- 1 From standby select [Menu > Settings > the Connectivity tab > Bluetooth > Handsfree > My Handsfree > New Handsfree](#).
- 2 Scroll to a device and select [Add](#).

Power save

You can save battery power with this function. You can only connect with a single Bluetooth device. You must turn this function off if you want to connect with more than one Bluetooth device at the same time.

To turn powersave on

- From standby select [Menu > Settings > the Connectivity tab > Bluetooth > Powersave > On](#).

Phone name

You can enter a name for your phone to be shown when other devices find it.

To enter a phone name

- 1 From standby select [Menu > Settings > the Connectivity tab > Bluetooth > Phone Name](#).
- 2 Enter the phone name and select [OK](#).

Visibility

If you want other Bluetooth devices to be able to discover your phone, you can choose to make your phone visible.

To show your phone

- From standby select [Menu > Settings > the Connectivity tab > Bluetooth > Visibility > Show Phone](#).

Exchanging items

Send or receive items using Bluetooth wireless technology as the transfer method. Choose a device from the list of found devices.

To send a contact

- 1 From standby select **Menu > Contacts**.
- 2 Scroll to a contact and select **More > Send Contact > Via Bluetooth**.
- 3 Select the device to send the item to.

To receive an item

- 1 From standby select **Menu > Settings > the Connectivity tab > Bluetooth > Turn On**.
- 2 Select **Visibility > Show Phone**.
- 3 When you receive an item, follow the instructions on the screen.

Transferring sound to and from a Bluetooth handsfree

You can transfer the sound to and from a Bluetooth handsfree using a phone key or the handsfree key.

To transfer sound

- 1 From standby select **Menu > Settings > the Connectivity tab > Bluetooth > Handsfree > Incoming Call**.
- 2 Select an option. In **Phone** transfers sound to the phone. In **Handsfree** transfers sound to the handsfree.

File transfer

You can synchronize and transfer files using Bluetooth wireless technology. See *Synchronization using a computer* on page 51.

Using the USB Cable

You can connect your phone to a computer with the USB cable to transfer files using **File Transfer**. You can also synchronize, transfer files and use your phone as a modem using **Phone Mode**. For more information go to the *Getting started* section at www.sonyericsson.com/support.

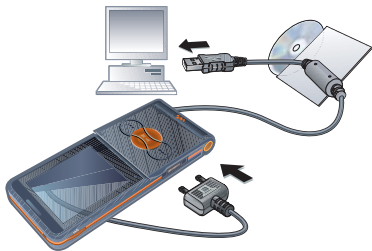

Before you use the USB cable

- See *Required operating systems* on page 18.
- ! Only use a USB cable supported by your phone. Do not remove the USB cable from your phone or computer during file transfer as this may corrupt the phone memory or the memory card.

To disconnect the USB cable safely

- 1 Right-click the removable disk icon in *Windows Explorer*.
- 2 Select *Eject*.
- 3 Disconnect the USB cable when the following message is shown in the phone: *USB connections ended. It is now safe to remove the USB cable.*

Drag and drop media files

You can drag and drop media files between your phone or memory card and a computer in *Microsoft Windows Explorer*.

To drag and drop media files

- 1 Connect your phone to a computer with the USB cable.
- 2 Phone: Select [File Transfer](#). The phone will remain activated during file transfer.
- 3 Computer: Wait until the phone memory and memory card appear as external disks in *Windows Explorer*.
- 4 Drag and drop selected files between the phone and the computer.

Synchronizing

You can synchronize in two different ways:

- You can use the USB cable or Bluetooth wireless technology to synchronize phone contacts,

appointments, tasks and notes with a computer program such as Microsoft Outlook®.

- You can also synchronize with an Internet service. For more information go to the Getting started section at www.sonyericsson.com/support.



Use only one of the synchronization methods at a time with your phone.

Synchronization using a computer

Before synchronizing you need to install *the Sony Ericsson PC Suite*.



Sony Ericsson PC Suite is included on the CD with your phone and available for download at www.sonyericsson.com/support.

See *Required operating systems* on page 18.

To install the Sony Ericsson PC Suite

- 1 Turn on your computer and insert the CD. The CD starts automatically and the installation window opens.
- If the CD does not start click *Start/Run...* and type *D:start.exe* and click *OK*.
- 2 Select a language and click *OK*.
- 3 Click *Install Sony Ericsson PC Suite* and follow the instructions on the screen.

To synchronize using the PC Suite

- 1 **Computer:** Start *PC Suite* from *Start/Programs/Sony Ericsson/PC Suite*.
- 2 Follow the instructions in the PC Suite for how to connect.
- 3 **Phone:** Select [Phone Mode](#).
- 4 **Computer:** When you are notified that the *Sony Ericsson PC Suite* has found your phone, you can start using the phone mode applications.



For usage details, see the Sony Ericsson PC Suite Help section once the software has been installed on your computer.

Synchronization using an Internet service

You can synchronize online using an Internet service with your phone. If Internet settings are not in your phone, see *Settings* on page 46.

Before you start to synchronize using an Internet service

You must enter settings for remote synchronization and register a synchronization account online with a service provider. Settings that are required are:

- [Server Address](#) – server URL.
- [Username](#) – account username.
- [Password](#) – account password.
- [Connection](#) – select an Internet profile.

- [Applications](#) – mark applications to synchronize.
- [App. Settings](#) – select an application and enter a database name, and if required, username and password.
- [Sync. Interval](#) – set how often to synchronize.
- [Remote Initiation](#) – select an option to use when you start synchronization from a service.
- [Remote Security](#) – enter a server ID and a server password.

To enter settings for remote synchronization

- 1 From standby select [Menu](#) > [Organizer](#) > [Synchronization](#).
- 2 Scroll to [New Account](#) and select [Add](#).
- 3 Enter a name for the new account and select [Continue](#).
- 4 Enter the settings and select [Save](#).

To delete an account

- 1 From standby select [Menu](#) > [Organizer](#) > [Synchronization](#).
- 2 Scroll to an account and select [More](#) > [Delete](#).

To start remote synchronization

- 1 From standby select [Menu](#) > [Organizer](#) > [Synchronization](#).
- 2 Scroll to an account and select [Start](#).



Update Service

You can update your phone with the latest software. You do not lose personal or phone information.

There are two ways to update your phone:

- Over the air using your phone
- Using the provided USB cable and an Internet-connected computer

- ! *The update service requires data access (GPRS).*

Before you use the Update service
If settings are not in your phone, see *Settings* on page 46.

To view the current software in the phone

- 1 From standby select [Menu > Settings > the General tab > Update Service](#).
- 2 Select [Software Version](#).

To use Update service using the phone

- 1 From standby select [Menu > Settings > the General tab > Update Service](#).
- 2 Select [Search For Update](#) and follow the instructions on the screen.

To use Update service using a USB cable

- 1 Go to www.sonyericsson.com/support or click the *Sony Ericsson Update service* in the *PC Suite* software if installed on your computer. See *To install the Sony Ericsson PC Suite* on page 51.
- 2 Select a region and country.
- 3 Follow the instructions on the screen.

To set a reminder to use Update service

- 1 From standby select [Menu > Settings > the General tab > Update Service > Reminder](#).
- 2 Select an option.

More Features

Alarms

You can set a sound or the radio as an alarm signal. The alarm sounds even if the phone is set to silent or turned off. When the alarm sounds you can silence it for 9 minutes or turn it off.

To set the alarm

- 1 From standby select **Menu** > **Organizer** > **Alarms**.
- 2 Scroll to an alarm and select **Edit**.
- 3 Scroll to **Time:** and select **Edit**.
- 4 Enter a time and select **OK** > **Save**.

To set the recurring alarm

- 1 From standby select **Menu** > **Organizer** > **Alarms**.
- 2 Scroll to an alarm and select **Edit**.
- 3 Scroll to **Recurrent:** and select **Edit**.
- 4 Scroll to a day and select **Mark**.
- 5 Select **Done** > **Save**.

To set the alarm signal

- 1 From standby select **Menu** > **Organizer** > **Alarms**.
- 2 Scroll to an alarm and select **Edit**.
- 3 Scroll to **Alarm Signal:** and select **Edit**.
- 4 Scroll to an option and select **Save**.

To silence the alarm

- When the alarm sounds, press any key.

To silence the radio alarm

- When the alarm sounds, select **Snooze**.

To turn off an alarm

- When the alarm sounds, select **Turn Off**.

To cancel the alarm

- 1 From standby select **Menu** > **Organizer** > **Alarms**.
- 2 Scroll to an alarm and select **Turn Off**.

Calendar

The calendar can be synchronized with a computer calendar or with a calendar on the Web. See *Synchronizing* on page 51.

Appointments

You can add new appointments or reuse existing appointments.

To add an appointment

- 1 From standby select **Menu** > **Organizer** > **Calendar**.
- 2 Select a date.
- 3 Scroll to **New Appointment** and select **Add**.
- 4 Enter the information and confirm each entry.
- 5 Select **Save**.

To view an appointment

- 1 From standby select **Menu** > **Organizer** > **Calendar**.
- 2 Select a date.
- 3 Scroll to an appointment and select **View**.

To reuse an existing appointment

- 1 From standby select **Menu** > **Organizer** > **Calendar**.
- 2 Select a date.
- 3 Scroll to an appointment and select **View**.
- 4 Select **More** > **Edit**.
- 5 Edit the appointment and confirm each entry.
- 6 Select **Save**.

To send an appointment

- 1 From standby select **Menu** > **Organizer** > **Calendar**.
- 2 Select a date.
- 3 Scroll to an appointment and select **More** > **Send**.
- 4 Select a transfer method.

- ! *Make sure the receiving device supports the transfer method you select.*

To view a calendar week

- 1 From standby select **Menu** > **Organizer** > **Calendar**.
- 2 Select a date.
- 3 Select **More** > **View Week**.

To set when reminders should sound

- 1 From standby select **Menu** > **Organizer** > **Calendar**.
- 2 Select a date.
- 3 Select **More** > **Advanced** > **Reminders**.
- 4 Select an option.

- ! *A reminders option set in calendar affects a reminders option set in tasks.*

Navigating your calendar

You can use the navigation key to move between days or weeks. In the monthly view, you can use keypad shortcuts.

Key	Shortcut
	Back a week
	Back a month
	Back a year
	Today's date
	Next week
	Next month
	Next year

Calendar settings

To view calendar options

- 1 From standby select **Menu > Organizer > Calendar**.
- 2 Select **More**.

Tasks

You can add new tasks or reuse existing tasks.

To add a task

- 1 From standby select **Menu > Organizer > Tasks**.
- 2 Select **New Task > Add**.
- 3 Select an option.
- 4 Enter details and confirm each entry.

To view a task

- 1 From standby select **Menu > Organizer > Tasks**.
- 2 Scroll to a task and select **View**.

To reuse an existing task

- 1 From standby select **Menu > Organizer > Tasks**.
- 2 Scroll to a task and select **View**.
- 3 Select **More > Edit**.
- 4 Edit the task and select **Continue**.
- 5 Choose to set a reminder.

To send a task

- 1 From standby select **Menu > Organizer > Tasks**.
- 2 Scroll to a task and select **More > Send**.
- 3 Select a transfer method.

! *Make sure the receiving device supports the transfer method you select.*

To set when reminders should sound

- 1 From standby select **Menu > Organizer > Tasks**.
- 2 Scroll to a task and select **More > Reminders**.
- 3 Select an option.

! *A reminders option set in tasks affects a reminders option set in calendar.*

Notes

You can make notes and save them. You can also show a note in standby.

To add a note

- 1 From standby select **Menu > Organizer > Notes**.
- 2 Select **New Note > Add**.
- 3 Write a note and select **Save**.

To show a note in standby

- 1 From standby select **Menu > Organizer > Notes**.
- 2 Scroll to a note and select **More > Show in Standby**.

To edit a note

- 1 From standby select **Menu** > **Organizer** > **Notes**.
- 2 Scroll to a note and select **More** > **Edit**.
- 3 Edit the note and select **Save**.

To send a note

- 1 From standby select **Menu** > **Organizer** > **Notes**.
- 2 Scroll to a note and select **More** > **Send**.
- 3 Select a transfer method.

 *Make sure the receiving device supports the transfer method you select.*

Timer, Stopwatch and Calculator



To use the timer

- 1 From standby select **Menu** > **Organizer** > **Timer**.
- 2 Enter the hours, minutes and seconds.
- 3 Select **Start**.

To use the stopwatch

- 1 From standby select **Menu** > **Organizer** > **Stopwatch** > **Start**.
- 2 To view a new lap time, select **New Lap**.

To use the calculator

- 1 From standby select **Menu** > **Organizer** > **Calculator**.
- 2 Press  or  to select \div \times $-$ $+$ $.$ $\%$ $=$.

Code Memo

You can save security codes, for example, for credit cards. You must set a passcode to open the code memo.

Checkword

The checkword confirms that you have entered the correct passcode. If the passcode is correct, the correct codes are shown. If the passcode is incorrect, the checkword and the codes shown are also incorrect.

To open code memo for the first time

- 1 From standby select **Menu** > **Organizer** > **Code Memo**.
- 2 Follow the instructions on the screen and select **Continue**.
- 3 Enter a passcode and select **Continue**.
- 4 Confirm the passcode and select **Continue**.
- 5 Enter a checkword and select **Done**.

To add a code

- 1 From standby select **Menu** > **Organizer** > **Code Memo**.
- 2 Enter a passcode and select **New Code** > **Add**.
- 3 Enter a name associated with the code and select **Continue**.
- 4 Enter the code and select **Done**.

To change a passcode

- 1 From standby select [Menu](#) > [Organizer](#) > [Code Memo](#).
- 2 Enter your passcode and select [More](#) > [Change Passcode](#).
- 3 Enter your new passcode and select [Continue](#).
- 4 Re-enter the new passcode and select [Continue](#).
- 5 Enter a checkword and select [Done](#).

Forget your passcode?

If you forget your passcode, you must reset the code memo. This means that all entries in the code memo are deleted. The next time you enter the code memo, you must proceed as if you are opening it for the first time. See *To open code memo for the first time* on page 57.

To reset code memo

- 1 From standby select [Menu](#) > [Organizer](#) > [Code Memo](#).
- 2 Enter any passcode to access the code memo. The checkword and codes that are then shown are incorrect.
- 3 Select [More](#) > [Reset](#).
- 4 [Reset code memo?](#) appears.
- 5 Select [Yes](#).

Profiles

Profiles automatically adapt your phone to different situations, for example, while in a meeting or when driving. Some profiles settings, for example, ring volume may be adjusted automatically to suit a certain area or accessory. You can reset all profile settings to how they were set when you bought your phone.

To select a profile

- 1 From standby select [Menu](#) > [Settings](#) > the [General](#) tab > [Profiles](#).
- 2 Select a profile.

To view and edit a profile

- 1 From standby select [Menu](#) > [Settings](#) > the [General](#) tab > [Profiles](#).
- 2 Scroll to a profile and select [More](#) > [View And Edit](#).



You cannot rename the Normal profile.

To reset all profiles

- 1 From standby select [Menu](#) > [Settings](#) > the [General](#) tab > [Profiles](#).
- 2 Scroll to a profile and select [More](#) > [Reset Profiles](#).

Time and Date

To set the time

- 1 From standby select **Menu** > **Settings** > the **General** tab > **Time & Date** > **Time**.
- 2 Enter the time and select **Save**.

To set the date

- 1 From standby select **Menu** > **Settings** > the **General** tab > **Time & Date** > **Date**.
- 2 Enter the date and select **Save**.

Themes

You can change the appearance of the screen through items such as colors and wallpaper. You can also create new themes and download them. For more information, go to www.sonyericsson.com/support.

To set a theme

- 1 From standby select **Menu** > **File Manager** > **Themes**.
- 2 Scroll to a theme and select **Set**.

Locks

SIM card lock

This lock only protects your subscription. Your phone will work with a new SIM card. If the lock is on, you have to enter a PIN (Personal Identity Number).

If you enter your PIN incorrectly three times in a row, the SIM card is blocked and you need to enter your PUK (Personal Unblocking Key). Your PIN and PUK are supplied by your network operator.

To unblock the SIM card

- 1 When **PIN Blocked** appears, enter your PUK and select **OK**.
- 2 Enter a new four-to-eight-digit PIN and select **OK**.
- 3 Re-enter the new PIN and select **OK**.

To edit the PIN

- 1 From standby select **Menu** > **Settings** > the **General** tab > **Security** > **Locks** > **SIM Protection** > **Change PIN**.
- 2 Enter your PIN and select **OK**.
- 3 Enter a new four-to-eight-digit PIN and select **OK**.
- 4 Re-enter the new PIN and select **OK**.

! *If Codes do not match. appears, you entered the new PIN incorrectly. If Wrong PIN. appears, followed by Old PIN:, you entered your old PIN incorrectly.*

To use the SIM card lock

- 1 From standby select **Menu** > **Settings** > the **General** tab > **Security** > **Locks** > **SIM Protection** > **Protection**.
- 2 Select an option.
- 3 Enter your PIN and select **OK**.

Phone lock

You can stop unauthorized use of your phone. Change the phone lock code (0000) to any four-to-eight-digit personal code.

- ! *It is important that you remember your new code. If you forget it, you have to take your phone to your local Sony Ericsson retailer.*

To use the phone lock

- 1 From standby select **Menu** > **Settings** > the **General** tab > **Security** > **Locks** > **Phone Protection** > **Protection**.
- 2 Select an option.
- 3 Enter the phone lock code and select **OK**.

To change the phone lock code

- 1 From standby select **Menu** > **Settings** > the **General** tab > **Security** > **Locks** > **Phone Protection** > **Change Code**.
- 2 Enter the old code and select **OK**.
- 3 Enter the new code and select **OK**.
- 4 Repeat the code and select **OK**.

IMEI Number

Keep a copy of your IMEI (International Mobile Equipment Identity) number in case your phone should be stolen.

To view your IMEI number

- From standby press ***#06#**, **#06#**, **0+**, **6**, **#06#**.

Troubleshooting

Why doesn't the phone work the way I want it to?

Some problems will require you to call your network operator.

What do I do if the flip comes off?

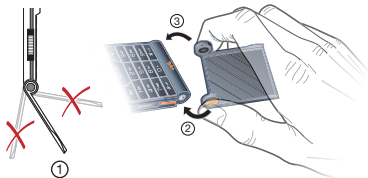

The flip is capable of being detached.

- 1 When you re-attach the flip it is important that the flip's angle is correct.
- 2 Place the flip's left hinge around the peg.
- 3 Gently pull the flip's right hinge in place. When the flip has been successfully replaced it snaps when you close it.

For more support go to www.sonyericsson.com/support.

Common Questions

I have problems with memory capacity or the phone is working slowly

Restart your phone every day to free memory or do a [Master Reset](#).

Master reset

If you select [Reset Settings](#), the changes that you have made to settings will be deleted.

If you select [Reset All](#), in addition to your changes to settings, all contacts, messages, personal data, and content that you have downloaded, received or edited will also be deleted.

To reset the phone

- 1 From standby select [Menu](#) > [Settings](#) > the [General](#) tab > [Master Reset](#) > [Reset Settings](#).
- 2 Follow the instructions on the screen and select [Continue](#).

I cannot charge the phone or battery capacity is low

The charger is not properly connected or the battery connection is poor. Remove the battery and clean the connectors.

The battery is worn out and needs to be replaced. See *Charging the Battery* on page 8.

No battery icon appears when I start charging the phone

It may take a few minutes before the battery icon appears on the screen.

Some menu options appear in gray

A service is not activated. Contact your network operator.

I cannot use SMS/text messages on my phone

Settings are missing or incorrect. Contact your network operator to find out the correct SMS service center setting. See *Text Messages* on page 31.

I cannot use picture messages on my phone

Your subscription does not include data capability. Settings are missing or incorrect. Please contact your network operator.

See *Help in Your Phone* on page 7 or go to www.sonyericsson.com/support to order settings and follow the instructions on the screen. See *Settings* on page 46.

How do I turn on and off T9 text input when writing a text message?

When you enter text, press and hold down **(*)aA**. You will see “T9” at the top of the text message when T9 is activated.

How do I change phone language?

- 1 From standby select **Menu > Settings > the General tab > Language > Phone Language**.
- 2 Select an option.

I cannot use the Internet

Your subscription does not include data capability. Internet settings are missing or incorrect. Please contact your network operator.

See *Help in Your Phone* on page 7 or go to www.sonyericsson.com/support to order Internet settings and follow the instructions on the screen. See *Settings* on page 46.

The phone cannot be detected by other devices using Bluetooth wireless technology

You have not turned the Bluetooth function on.

Make sure that the visibility is set to show phone. See *To receive an item* on page 50.

I cannot synchronize or transfer data between my phone and my computer when using the USB cable.

The cable or software that came with your phone has not been properly installed. Go to www.sonyericsson.com/support, to read Getting started guides which contain detailed installation instructions and troubleshooting guides.

Error Messages

Insert SIM.

There is no SIM card in your phone or you may have inserted it incorrectly.

See *Charging the Battery* on page 8.

The SIM card connectors need cleaning. If the card is damaged, contact your network operator.

Insert correct SIM card.

Your phone is set to work only with certain SIM cards. Check if you are using the correct operator SIM card.

Wrong PIN./Wrong PIN2.

You have entered your PIN or PIN2 incorrectly.

Enter the correct PIN or PIN2 and select **Yes**. See *To insert the SIM card* on page 5.

PIN Blocked/PIN2 blocked.

You have entered your PIN or PIN2 code incorrectly three times in a row.

To unblock, see *SIM card lock* on page 59.

Codes do not match.

Codes that you have entered do not match. When you want to change a security code, for example your PIN, you have to confirm the new code. See *SIM card lock* on page 59.

No Nwk Coverage

Your phone is in flight mode. See *Flight mode* on page 7.

Your phone is not receiving any radio signal, or the received signal is too weak. Contact your network operator and make sure that the network has coverage where you are.

The SIM card is not working properly. Insert your SIM card in another phone. If this works, it is probably your phone that is causing the problem. Please contact the nearest Sony Ericsson service location.

Emerg. Calls Only

You are within range of a network, but you are not allowed to use it. However, in an emergency, some network operators allow you to call the international emergency number 112. See *Emergency Calls* on page 23.

PUK blocked. Contact provider.

You entered your personal unblocking key code (PUK) incorrectly 10 times in a row.

Charging - Non-standard battery.

The battery that you are using is not a Sony Ericsson-approved battery. See *Battery* on page 67.

Important Information

Sony Ericsson Consumer Web site

On www.sonyericsson.com/support there is a support section where help and tips are only a few clicks away. Here you will find the latest computer software updates and tips on how to use your product more efficiently.

Service and support

You have access to a portfolio of exclusive service advantages such as:

- Global and local Web sites providing support
- A global network of Call Centers
- An extensive network of Sony Ericsson service partners
- A warranty period. Learn more about the warranty conditions in this User guide

On www.sonyericsson.com, you will find the latest support tools and information. For operator-specific services and features, please contact your network operator.

You can also contact our Call Centers. If your country/region is not represented in the list below, please contact your local dealer. (Calls are charged according to national rates, including local taxes, unless the phone number is a toll-free number.)

If your product needs service, please contact the dealer from whom it was purchased, or one of our service partners.

For warranty claims, save proof of purchase.

Support

Argentina	800-333-7427	questions.AR@support.sonyericsson.com
Australia	1-300650-600	questions.AU@support.sonyericsson.com
Belgique/België	02-7451611	questions.BE@support.sonyericsson.com
Brasil	4001-04444	questions.BR@support.sonyericsson.com
Canada	1-866-766-9374	questions.CA@support.sonyericsson.com
Central Africa	+27 112589023	questions.CF@support.sonyericsson.com
Chile	123-0020-0656	questions.CL@support.sonyericsson.com
Colombia	18009122135	questions.CO@support.sonyericsson.com
Česká republika	844550 055	questions.CZ@support.sonyericsson.com
Danmark	33 31 28 28	questions.DK@support.sonyericsson.com
Deutschland	0180 534 2020	questions.DE@support.sonyericsson.com
Ελλάδα	801-11-810-810 210-89 91 919	questions.GR@support.sonyericsson.com
España	902 180 576	questions.ES@support.sonyericsson.com
France	0 825 383 383	questions.FR@support.sonyericsson.com
Hong Kong/香港	8203 8863	questions.HK@support.sonyericsson.com
Hrvatska	062 000 000	questions.HR@support.sonyericsson.com
India/ भारत	39011111	questions.IN@support.sonyericsson.com
Indonesia	021-2701388	questions.ID@support.sonyericsson.com
Ireland	1850 545 888	questions.IE@support.sonyericsson.com
Italia	06 48895206	questions.IT@support.sonyericsson.com
Lietuva	8 70055030	questions.LT@support.sonyericsson.com
Magyarország	+36 1 880 4747	questions.HU@support.sonyericsson.com
Malaysia	1-800-889900	questions.MY@support.sonyericsson.com
México	01 800 000 4722	questions.MX@support.sonyericsson.com
Nederland	0900 899 8318	questions.NL@support.sonyericsson.com
New Zealand	0800-100150	questions.NZ@support.sonyericsson.com
Norge	815 00 840	questions.NO@support.sonyericsson.com
Österreich	0810 200245	questions.AT@support.sonyericsson.com
Pakistan	111 22 55 73 (92-21) 111 22 55 73	questions.PK@support.sonyericsson.com
Philippines/Pilipinas	02-6351860	questions.PH@support.sonyericsson.com
Polska	0 (prefiks) 22 6916200	questions.PL@support.sonyericsson.com
Portugal	808 204 466	questions.PT@support.sonyericsson.com
România	(+4021) 401 0401	questions.RO@support.sonyericsson.com
Россия	8 (495) 787 0986	questions.RU@support.sonyericsson.com

Schweiz/Suisse/Svizzera	0848 824 040
Singapore	67440733
Slovensko	02-5443 6443
South Africa	0861 6322222
Suomi	09-299 2000
Sverige	013-24 45 00
Türkiye	0212 473 77 71
Україна	(+0380) 44 590 1515
United Kingdom	08705 23 7237
United States	1-866-7669347
Venezuela	0-800-100-2250
الإمارات العربية المتحدة	43 919880
中国	4008100000
台灣	02-25625511
ไทย	02-2483030

questions.CH@support.sonyericsson.com
 questions.SG@support.sonyericsson.com
 questions.SK@support.sonyericsson.com
 questions.ZA@support.sonyericsson.com
 questions.FI@support.sonyericsson.com
 questions.SE@support.sonyericsson.com
 questions.TR@support.sonyericsson.com
 questions.UA@support.sonyericsson.com
 questions.GB@support.sonyericsson.com
 questions.US@support.sonyericsson.com
 questions.VE@support.sonyericsson.com
 questions.AE@support.sonyericsson.com
 questions.CN@support.sonyericsson.com
 questions.TW@support.sonyericsson.com
 questions.TH@support.sonyericsson.com

Guidelines for Safe and Efficient Use

Please follow these guidelines. Failure to do so might entail a potential health risk or product malfunction. If in doubt as to its proper function, have the product checked by a certified service partner before charging or using it.



Recommendations for safe use of our products

- Handle with care and keep in a clean and dust-free place.
- **Warning!** May explode if disposed of in fire.
- Do not expose your product to liquid or moisture or excess humidity.
- Do not expose to extreme temperatures. Do not expose the battery to temperatures above +140°F (+60°C).



- Do not expose to flames or lit tobacco products.
- Do not drop, throw or try to bend your product.



- Do not paint or attempt to disassemble or modify your product. Only Sony Ericsson authorized personnel should perform service.
- Consult with authorized medical staff and the instructions of the medical device manufacturer before using your product near pacemakers or other medical devices or equipment.
- Discontinue use of electronic devices or disable the radio transmitting functionality of the device where required or requested to do so.
- Do not use where a potentially explosive atmosphere exists.
- Do not place your product or install wireless equipment in the area above an air bag in your car.
- Caution: Cracked or broken displays may create sharp edges or splinters that could be harmful upon contact.
- Do not use your Bluetooth Headset in positions where it is uncomfortable or will be subject to pressure.



CHILDREN

Warning! Keep out of the reach of children. Do not allow children to play with phones or accessories. They could hurt themselves or others. Products may contain small parts that could become detached and create a choking hazard.



Power supply (Charger)

Connect the charger to power sources as marked on the product. Do not use outdoors or in damp areas. Do not alter or subject the cord to damage or stress. Unplug the unit before cleaning it. Never alter the plug. If it does not fit into the outlet, have a proper outlet installed by an electrician. When power supply is connected there is a small drain of power. To avoid this small energy waste, disconnect the power supply when the product is fully charged. Use of charging devices that are not Sony Ericsson branded may impose increased safety risks.

Battery

New or idle batteries can have short-term reduced capacity. Fully charge the battery before initial use. Use for intended purpose only. Charge the battery in temperatures between +41°F (+5°C) and +113°F (+45°C). Do not put the battery into your mouth. Do not let the battery contacts touch another metal object. Turn off the product before removing the battery. Performance depends on temperatures, signal strength, usage patterns, features selected and voice or data transmissions. Only Sony Ericsson service partners should remove or replace built-in batteries. Use of batteries that are not Sony Ericsson branded may pose increased safety risks.

Personal medical devices

Phones may affect implanted medical equipment. Reduce risk of interference by keeping a minimum distance of 6 inches (15 cm) between the phone and the device. Use the phone at your right ear. Do not carry the phone in your breast pocket. Turn off the phone if you suspect interference. For all medical devices, consult a physician and the manufacturer.

Driving

Some vehicle manufacturers forbid the use of phones in their vehicles unless a handsfree kit with an external antenna supports the installation. Check with your vehicle manufacturer's representative to be sure that your phone or Bluetooth handsfree will not affect the electronic systems in your vehicle. Full attention should be given to driving at all times and local laws and regulations restricting the use of wireless devices while driving must be observed.

GPS/Location based functions

Some products provide GPS/Location based functions. Location determining functionality is provided "As is" and "With all faults". Sony Ericsson does not make any representation or warranty as to the accuracy of such location information. Use of location-based information by the device may not be uninterrupted or error free and may additionally be dependent on network service availability. Please note that functionality may be reduced or prevented in certain environments such as building interiors or areas adjacent to buildings. **Caution:** Do not use GPS functionality in a manner which causes distraction from driving.

Emergency calls

Calls cannot be guaranteed under all conditions. Never rely solely upon phones for essential communications. Calls may not be possible in all areas, on all networks, or when certain network services and/or phone features are used.

Antenna

Use of antenna devices not marketed by Sony Ericsson could damage your phone, reduce performance, and produce SAR levels above the established limits. Do not cover the antenna with your hand as this affects call quality, power levels and can shorten talk and standby times.

Efficient use

Hold your phone as you would any other phone. Do not cover the top of the phone when it is in use, as this affects call quality and may cause the phone to operate at a higher power level than needed, thus shortening talk and standby times.

Radio frequency (RF) exposure and Specific Absorption Rate (SAR)

When your phone or Bluetooth handsfree is turned on, it emits low levels of radio frequency energy. International safety guidelines have been developed through periodic and thorough evaluation of scientific studies. These guidelines establish permitted levels of radio wave exposure. The guidelines include a safety margin designed to assure the safety of all persons and to account for any variations in measurements.

Specific Absorption Rate (SAR) is used to measure radio frequency energy absorbed by the body when using a phone. The SAR value is determined at the highest certified power level in laboratory conditions, but because the phone is designed to use the minimum power necessary to access the chosen

network, the actual SAR level can be well below this value. There is no proof of difference in safety based on difference in SAR value.

Products with radio transmitters sold in the US must be certified by the Federal Communications Commission (FCC). When required, tests are performed when the phone is placed at the ear and when worn on the body. For body-worn operation, the phone has been tested when positioned a minimum of 15 mm from the body without any metal parts in the vicinity of the phone or when properly used with an appropriate Sony Ericsson accessory and worn on the body.

For more information about SAR and radio frequency exposure go to: www.sonyericsson.com/health.

Malware

Malware (short for malicious software) is software that can harm your phone or other computers. Malware or harmful applications can include viruses, worms, spyware, and other unwanted programs. While your device does employ security measures to resist such efforts, Sony Ericsson does not warrant or represent that your device will be impervious to introduction of malware. You can however reduce the risk of malware attacks by using care when downloading content or accepting applications, refraining from opening or responding to messages from unknown sources, using trustworthy services to access the Internet, and only downloading content to your phone from known, reliable sources.

Accessories

Use only Sony Ericsson branded original accessories and certified service partners. Sony Ericsson does not test third-party accessories. Accessories may influence RF Exposure, radio performance, sound loudness, electric safety and other areas. Third-party accessories and parts may pose a risk to your health or safety or decrease performance.

Accessible Solutions/Special Needs

In the US, compatible Sony Ericsson phones may offer compatibility with TTY terminals (with use of necessary accessory). For more information call the Sony Ericsson Special Needs Center on 877 878 1996 (TTY) or 877 207 2056 (voice), or go to www.sonyericsson-snc.com.

Disposal of old electrical and electronic equipment

Electronic equipment and batteries should not be included as household waste but should be left at an appropriate collection point for recycling. This helps prevent potential negative consequences for the environment and human health. Check local regulations by contacting your local city office, your household waste disposal service, the shop where you purchased the product or calling a Sony Ericsson Call Center.



Disposing of the battery

Check local regulations or call a Sony Ericsson Call Center for information. Never use municipal waste.



Memory card

If your product comes complete with a removable memory card, it is generally compatible with the phone purchased but may not be compatible with other devices or the capabilities of their memory cards. Check other devices for compatibility before purchase or use. If your product is equipped with a memory card reader, check memory card compatibility before purchase or use.

Memory cards are generally formatted prior to shipping. To reformat the memory card, use a compatible device. Do not use the standard operating system format when formatting the

memory card on a PC. For details, refer to the operating instructions of the device or contact customer support.

WARNING:

If your device requires an adapter for insertion into the phone or another device, do not insert the card directly without the required adapter.

Precautions on Memory Card Use

- Do not expose the memory card to moisture.
- Do not touch terminal connections with your hand or any metal object.
- Do not strike, bend, or drop the memory card.
- Do not attempt to disassemble or modify the memory card.
- Do not use or store the memory card in humid or corrosive locations or in excessive heat such as a closed car in summer, in direct sunlight or near a heater, etc.
- Do not press or bend the end of the memory card adapter with excessive force.
- Do not let dust or foreign objects get into the insert port of any memory card adapter.
- Check you have inserted the memory card correctly.
- Insert the memory card as far as it will go into any memory card adapter needed. The memory card may not operate properly unless fully inserted.
- We recommend that you make a backup copy of important data. We are not responsible for any loss or damage to content you store on the memory card.
- Recorded data may be damaged or lost when you remove the memory card or memory card adapter. Turn off the power while formatting, reading or writing data. Do not use the memory card in locations subject to static electricity or high electrical field emissions.

Protection of personal information

Erase personal data before disposing of the product. To delete data, perform a master reset. Deleting data from the phone memory does not ensure that it cannot be recovered. Sony Ericsson does not warrant against recovery of information and does not assume responsibility for disclosure of any information even after a master reset.

Accessories

Sony Ericsson recommends use of Sony Ericsson original accessories for safe and efficient use of its products. Use of third-party accessories may decrease performance or pose a risk to your health or safety.

LOUDNESS WARNING:

Avoid volume levels that may be harmful to your hearing.

End User License Agreement

Software delivered with this device and its media is owned by Sony Ericsson Mobile Communications AB, and/or its affiliated companies and its suppliers and licensors.

Sony Ericsson grants you a non-exclusive limited license to use the Software solely in conjunction with the Device on which it is installed or delivered. Ownership of the Software is not sold, transferred or otherwise conveyed.

Do not use any means to discover the source code or any component of the Software, reproduce and distribute the Software, or modify the Software. You are entitled to transfer rights and obligations to the Software to a third party, solely together with the Device with which you received the Software, provided the third party agrees in writing to be bound by the terms of this License.

This license exists throughout the useful life of this Device. It can be terminated by transferring your rights to the Device to a third party in writing.

Failure to comply with any of these terms and conditions will terminate the license immediately. Sony Ericsson and its third party suppliers and licensors retain all rights, title and interest in and to the Software. Sony Ericsson, and, to the extent that the Software contains material or code of a third party, such third party, shall be entitled third party beneficiaries of these terms.

This license is governed by the laws of Sweden. When applicable, the foregoing applies to statutory consumer rights.

In the event Software accompanying or provided in conjunction with your device is provided with additional terms and conditions, such provisions shall also govern your possession and usage of the Software.

Limited Warranty

Sony Ericsson Mobile Communications AB, Nya Vattentornet, SE-221 88 Lund, Sweden, (Sony Ericsson) or its local affiliated company, provides this Limited Warranty for your phone, original accessory delivered with your phone, and/or your mobile computing product (hereinafter referred to as "Product").

Should your Product need warranty service, please return it to the dealer from whom it was purchased, or contact your local Sony Ericsson Call Center (national rates may apply) or visit www.sonyericsson.com to get further information.

Our warranty

Subject to the conditions of this Limited Warranty, Sony Ericsson warrants this Product to be free from defects in design, material and workmanship at the time of its original purchase by a consumer. This Limited Warranty will last for a period of one (1) year as from the original date of purchase of the Product.

What we will do

If, during the warranty period, this Product fails to operate under normal use and service, due to defects in design, materials or workmanship, Sony Ericsson authorized distributors or service partners, in the country* where you purchased the Product, will, at their option, either repair or replace the Product in accordance with the terms and conditions stipulated herein.

Sony Ericsson and its service partners reserve the right to charge a handling fee if a returned Product is found not to be under warranty according to the conditions below.

Please note that some of your personal settings, downloads and other information may be lost when your Sony Ericsson Product is repaired or replaced. At present Sony Ericsson may be prevented by applicable law, other regulation or technical restrictions from making a backup copy of certain downloads. Sony Ericsson does not take any responsibility for any lost information of any kind and will not reimburse you for any such loss.

You should always make backup copies of all the information stored on your Sony Ericsson Product such as downloads, calendar and contacts before handing in your Sony Ericsson Product for repair or replacement.

Conditions

- 1 This Limited Warranty is valid only if the original proof of purchase for this Product issued by a Sony Ericsson authorized dealer specifying the

date of purchase and serial number**, is presented with the Product to be repaired or replaced.

Sony Ericsson reserves the right to refuse warranty service if this information has been removed or changed after the original purchase of the Product from the dealer.

- 2 If Sony Ericsson repairs or replaces the Product, the repair for the defect concerned, or the replaced Product shall be warranted for the remaining time of the original warranty period or for ninety (90) days from the date of repair, whichever is longer. Repair or replacement may involve the use of functionally equivalent reconditioned units. Replaced parts or components will become the property of Sony Ericsson.
- 3 This warranty does not cover any failure of the Product due to normal tear and wear, or due to misuse, including but not limited to use in other than the normal and customary manner, in accordance with the Sony Ericsson instructions for use and maintenance of the Product. Nor does this warranty cover any failure of the Product due to accident, software or hardware modification or adjustment, acts of God or damage resulting from liquid. A rechargeable battery can be charged and discharged more than a hundred times. However, it will eventually wear out - this is not a defect and corresponds to normal wear and tear. When the talk-time or standby time is noticeably shorter, it is time to replace your battery. Sony Ericsson recommends that you use only batteries and chargers approved by Sony Ericsson. Minor variations in display brightness and color may occur between the phones. There may be tiny bright or dark dots on the display. These are called defective pixels and occur when individual dots have malfunctioned and can not be adjusted. Two defective pixels are deemed acceptable. Minor variations in camera image appearance may occur between phones. This is nothing uncommon and is not regarded as a defective camera module.

- 4 Since the cellular system on which the Product is to operate is provided by a carrier independent from Sony Ericsson, Sony Ericsson will not be responsible for the operation, availability, coverage, services or range of that system.
- 5 This warranty does not cover Product failures caused by installations, modifications, or repair or opening of the Product performed by a non-Sony Ericsson authorized person.
- 6 The warranty does not cover Product failures which have been caused by use of accessories or other peripheral devices which are not Sony Ericsson branded original accessories intended for use with the Product.
- 7 Tampering with any of the seals on the Product will void the warranty.
- 8 THERE ARE NO EXPRESS WARRANTIES, WHETHER WRITTEN OR ORAL, OTHER THAN THIS PRINTED LIMITED WARRANTY. ALL IMPLIED WARRANTIES, INCLUDING WITHOUT LIMITATION THE IMPLIED WARRANTIES OF MERCHANTABILITY OR FITNESS FOR A PARTICULAR PURPOSE, ARE LIMITED TO THE DURATION OF THIS LIMITED WARRANTY. IN NO EVENT SHALL SONY ERICSSON OR ITS LICENSORS BE LIABLE FOR INCIDENTAL OR CONSEQUENTIAL DAMAGES OF ANY NATURE WHATSOEVER, INCLUDING BUT NOT LIMITED TO LOST PROFITS OR COMMERCIAL LOSS; TO THE FULL EXTENT THOSE DAMAGES CAN BE DISCLAIMED BY LAW.

Some countries/states do not allow the exclusion or limitation of incidental or consequential damages, or limitation of the duration of implied warranties, so the preceding limitations or exclusions may not apply to you.

The warranty provided does not affect the consumer's statutory rights under applicable legislation in force, nor the consumer's rights against the dealer arising from their sales/purchase contract.

* Geographical scope of the warranty

If you have purchased your Product in a country member of the European Economic Area (EEA) or in Switzerland or the Republic of Turkey, and such Product was intended for sale in the EEA or in Switzerland or in Turkey, you can have your Product serviced in any EEA country or in Switzerland or in Turkey, under the warranty conditions prevailing in the country in which you require servicing, provided that an identical Product is sold in such country by an authorized Sony Ericsson distributor. To find out if your Product is sold in the country you are in, please call the local Sony Ericsson Call Center. Please observe that certain services may not be possible elsewhere than in the country of original purchase, for example due to the fact that your Product may have an interior or exterior which is different from equivalent models sold in other countries. Please note in addition that it may sometimes not be possible to repair SIM-locked Products.

** In some countries/regions additional information (such as a valid warranty card) may be requested.

FCC Statement

This device complies with Part 15 of the FCC rules. Operation is subject to the following two conditions:



(1) This device may not cause harmful interference, and (2) This device must accept any interference received, including interference that may cause undesired operation.

Any change or modification not expressly approved by Sony Ericsson may void the user's authority to operate the equipment.

This equipment has been tested and found to comply with the limits for a Class B digital device, pursuant to Part 15 of the FCC Rules. These limits are designed to provide reasonable protection against harmful interference in a residential

installation. This equipment generates, uses and can radiate radio frequency energy and, if not installed and used in accordance with the instructions, may cause harmful interference to radio communications. However, there is no guarantee that interference will not occur in a particular installation.

If this equipment does cause harmful interference to radio or television reception, which can be determined by turning the equipment off and on, the user is encouraged to try to correct the interference by one or more of the following measures:

- Reorient or relocate the receiving antenna.
- Increase the separation between the equipment and receiver.
- Connect the equipment into an outlet on a circuit different from that to which the receiver is connected.
- Consult the dealer or an experienced radio/TV technician for help.

Industry Canada Statement

This device complies with RSS-210 of Industry Canada.

Operation is subject to the following two conditions: (1) this device may not cause interference, and (2) this device must accept any interference, including interference that may cause undesired operation of the device.

This Class B digital apparatus complies with Canadian ICES-003.

Cet appareil numérique de la classe B est conforme à la norme NMB-003 du Canada.

Declaration of Conformity for W350a

We, Sony Ericsson Mobile Communications AB of Nya Vattentornet

SE-221 88 Lund, Sweden

declare under our sole responsibility that our product **Sony Ericsson type AAB-1022121-BV** and in combination with our accessories, to which this declaration relates is in conformity with the appropriate standards EN 301511:V9.0.2, EN 301489-7:V1.3.1, EN 301489-17:V1.2.1, EN 300328:V1.7.1 and EN 60950-1:2006, following the provisions of, Radio Equipment and Telecommunication Terminal Equipment directive 99/5/EC.

Lund, January 2008

CE 0682



Shoji Nemoto,

Head of Product Business Group GSM/UMTS

We fulfill the requirements of the R&TTE Directive (99/5/EC).

Index

A

alarms	54
answering service	27
applications	45
appointments	54
assembly	5
automatic redialing	22

B

battery	
charging	8
inserting	5
use and care	67
Bluetooth™ wireless technology	48
business cards	30
buttons	9, 13

C

calculator	57
calendar	54
call forward	27
call list	26
call numbers in message	32
call time	30
caller-specific ringtones	24
calls	
accepting	29
answering	23

handling two calls	28
international	22
making	22
putting on hold	27
recording	44
re-dialing	22
rejecting	23

camera

overview	39
settings	40
code memo	57
conference calls	28
contacts	
adding phone contacts	24
default contacts	23
groups of	26
synchronizing	51

D

date	59
declaration of conformity	73
downloading files	47

E

email	35
emergency calls	23

entering text	
multitap	17
T9™ Text Input	17
error messages	63
F	
file manager	15
fixed dialing	30
flight mode	7
G	
games	44
groups	26
H	
handsfree	18, 19
Bluetooth™ technology	49
help	7
I	
IMEI number	60
Internet	
bookmarks	46
profiles	47
security and certificates	47
settings	46
J	
Java™	45

K	
keys	9, 13
L	
lock	
phone	60
SIM card	59
M	
master reset	61
Media Manager	18
memory card	15
memory status	25
menu overview	11
menus	13
message templates	34
messages	31
area and cell information	38
email	35
picture message	32
templates	34
text message	31
voice	34
microphone	23
music	
transferring	18
music files	20
music key lock	9, 21

music keys	19
music player	18
MusicDJ™	43
My friends	37
my numbers	29

N

navigating menus	13
notes	56

P

phone	
language	17
lock	60
phone overview	9
picture message	32
pictures	41
PIN code	
changing	59
playlists	20
PlayNow™	21
profiles	58
PUK	59
push email	37

R

radio	42
restricted calls	29
ringtones	42
RSS reader	48

S

safety guidelines	66
sending	
business cards	30
melodies and ringtones	43
music	21
pictures	41
settings	
Internet	46
Java™	45
shortcuts	15
SIM card	
copying from	25
copying to	24
inserting	5
lock and unblock	59
sound recorder	44
speed dialing	26
standby	7
startup screen	7
stopwatch	57
submenus	13
synchronizing	51

T

tasks	56
text	17
text message	31
themes	59
time	59

timer	57	U	
TrackID™	22	unlock SIM card	59
transfer method		update service	53
Bluetooth™ technology	48	V	
USB	50	vibrating alert	43
transferring		video player	44
files	50	voice messages	34
music	18	voicemail	27
transferring pictures	40	volume	
troubleshooting	61	ear speaker	23
turn on the phone	6	ringtone	43
turning on/off		W	
phone lock	60	Walkman® player	18
SIM lock protection	60	warranty	70
		Z	
		zoom	39